



**USER'S MANUAL**  
**P7000 SERIES**

**P7000 SERIES**  
**HYDRAULIC PRESSURE STANDARD**  
**USER'S MANUAL**

Manufactured by;

GE RUSKA

RUSKA INSTRUMENT CORPORATION  
10311 WESTPARK DRIVE, HOUSTON, TEXAS 77042  
(713) 975-0547 FAX (713) 975-6338  
ruska@ruska.com

Release: PMAN-126-1D01  
Revision: A  
Date: 01/07/03

## **WARRANTY**

GE Ruska warrants its products to conform to or exceed the specifications as set forth in its catalogs in use at the time of sale and reserves the right, at its own discretion, without notice and without making similar changes in articles previously manufactured, to make changes in materials, designs, finish, or specifications. GE Ruska warrants products of its own factory against defects of material or workmanship for a period of one year from date of shipment.

Liability of GE Ruska under this warranty shall be limited to replacing, free of charge (FOB Houston, Texas), any such parts proving defective within the period of this warranty, but will not be responsible for transportation charges or consequential damages.

This warranty is not made for products manufactured by others which are illustrated and described in GE Ruska catalogs or incorporated in GE Ruska products in essentially the same form as supplied by the original manufacturer. However, GE Ruska agrees to use its best efforts to have original suppliers make good their warranties.

## **COPYRIGHT NOTICE**

Copyright © 2003 by GE Ruska. All rights reserved. This document may not be reproduced in part or in whole without the express written consent of GE Ruska.

## **DISCLAIMER**

No representations or warranties are made with respect to the contents of this user's manual. Further, GE Ruska reserves the right to revise this manual and to make changes from time to time in the content hereof without obligation to notify any person of such revision.

## **REVISION NOTICE**

RELEASE NUMBER	REVISION	DATE OF REVISION	DESCRIPTION
PMAN-126-1D01	A	01/07/03	Original release.

## **WARNING**

PRESSURIZED VESSELS AND ASSOCIATED EQUIPMENT ARE POTENTIALLY DANGEROUS. THE APPARATUS DESCRIBED IN THIS MANUAL SHOULD BE OPERATED ONLY BY PERSONNEL TRAINED IN PROCEDURES THAT WILL ASSURE SAFETY TO THEMSELVES, TO OTHERS, AND TO THE EQUIPMENT.

# I N D E X

## HYDRAULIC PRESSURE STANDARDS P7000 SERIES

SECTION		PAGE
1.0	GENERAL INFORMATION	1
2.0	CORRECTIONS	2
	2.1 Gravity	2
	2.2 Temperature	3
	2.3 Air Density	3
	2.4 Head of Fluid	3
	2.5 Piston and Cylinder (PCU) Deformation	4
	2.6 Piston Float Height	4
	2.7 Verticality	4
	2.8 Fluid Buoyancy and Loading	4
	2.9 Surface Tension	5
	2.10 Thermal Stability	5
3.0	CALCULATIONS	6
	3.1 Pressure Calculation	6
	3.2 Mass Calculation	9
4.0	NOMINAL PRESSURE GENERATED BY THE WEIGHTS	10
5.0	SUPPLIED AS STANDARD EQUIPMENT WITH EACH INSTRUMENT	11
6.0	SET UP FROM NEW	12
7.0	PRESSURE MEASURED CALIBRATION	14
8.0	PISTON CARE	16
	8.1 Piston Removal	16
	8.2 Piston Cleaning	16
	8.3 Cylinder Cleaning	16
	8.4 Piston Re-Assembly	17
	8.5 Refitting	17
	8.6 Piston Spin/Sensitivity	18
	8.7 Piston Increased Fall Rate	18

## INDEX - CONTINUED

SECTION		PAGE
9.0	GENERAL ARRANGEMENT DRAWINGS & PARTS LIST	21
10.0	ANCILLARY EQUIPMENT	26
11.0	FAULT FINDING	30
11.1	Poor Piston Spin/Sensitivity	30
11.2	System Will Not Prime or Pressurise	30
11.3	Piston Drops Quickly	30
11.4	Cannot Attain Maximum Pressure Having Screwed Capstan Fully In.	31
11.5	Hand Pump Malfunction	31
12.0	RECALIBRATION	32
13.0	SPECIFICATION	33
	APPENDIX A AIR DENSITY CHART	34
	APPENDIX B PISTON AND CYLINDER UNIT (REFERENCES AND RANGES)	35
	APPENDIX C COMPLETE SYSTEM, PCU AND MASS SET SELECTION TABLE	36



# USERS HANDBOOK

## HYDRAULIC PRESSURE STANDARDS

### P7000 SERIES

#### 1.0 GENERAL INFORMATION

The P7000 is a primary standard for pressure measurement. Utilising the well-proven Piston/Gauge system, consisting of a vertically mounted precision lapped Piston and Cylinder Unit (PCU), accurately calibrated weight masses (FORCE) are loaded on the Piston (AREA) which rises freely within its Cylinder. These Weights balance the upward force created by the pressure within the system.

$$\text{PRESSURE} = \frac{\text{FORCE}}{\text{AREA}}$$

Each weight is marked with the pressure standards serial number and a sequential number.

The pressure balance and any associated instruments are pressurised and therefore potentially dangerous. The pressure standard must be operated by personnel suitably trained to ensure their safety and that of the equipment.

**Do not exceed the pressure stated on the label of the pressure standard.**

Ensure that there is no pressure in the system by opening valve (7) before dismantling any part of the pressure system.

To ensure the best accuracy is attained, the instrument should be used in a draught free, thermally stable room. The benching should be sufficiently rigid so that it does not deflect under the load of the weight masses. The room should not have excess personnel movement.

All corrections in Section 2 should be considered and applied where necessary.

A full suite of PC based software is available to carry out all necessary calculations, see Section 10.1 Page 26

# USERS HANDBOOK

## HYDRAULIC PRESSURE STANDARDS

### P7000 SERIES

#### 1.0 GENERAL INFORMATION

The P7000 is a primary standard for pressure measurement. Utilising the well-proven Piston/Gauge system, consisting of a vertically mounted precision lapped Piston and Cylinder Unit (PCU), accurately calibrated weight masses (FORCE) are loaded on the Piston (AREA) which rises freely within its Cylinder. These Weights balance the upward force created by the pressure within the system.

$$\text{PRESSURE} = \frac{\text{FORCE}}{\text{AREA}}$$

Each weight is marked with the pressure standards serial number and a sequential number.

The pressure balance and any associated instruments are pressurised and therefore potentially dangerous. The pressure standard must be operated by personnel suitably trained to ensure their safety and that of the equipment.

**Do not exceed the pressure stated on the label of the pressure standard.**

Ensure that there is no pressure in the system by opening valve (7) before dismantling any part of the pressure system.

To ensure the best accuracy is attained, the instrument should be used in a draught free, thermally stable room. The benching should be sufficiently rigid so that it does not deflect under the load of the weight masses. The room should not have excess personnel movement.

All corrections in Section 2 should be considered and applied where necessary.

A full suite of PC based software is available to carry out all necessary calculations

As stated in Section 1:-

$$P = \frac{F}{A}$$

where

$$\begin{aligned} P &= \text{Pressure} \\ F &= \text{Force} \\ A &= \text{Area} \end{aligned}$$

Although by definition the pressure equation appears simple, to ensure accuracy when using the pressure standard the following effects must be considered:-

- Gravity
- Temperature
- Air density
- Head of fluid
- Piston and cylinder (PCU) deformation
- Piston float height
- Verticality
- Fluid buoyancy and loading
- Surface tension
- Thermal stability

The individual effect of each of the above are discussed throughout this section. Calculations for the above are covered in the next section.

## 2.1 Gravity

The downward force generated by the piston and weights is directly proportional to gravity. Gravity varies considerably with the latitude and altitude of the location. To ensure accuracy, gravity should be surveyed at the bench height to six significant figures.

To correct for gravity apply the following:-

$$F = M (G_l/G_s)$$

where

$$\begin{aligned} F &= \text{Downward force} \\ M &= \text{Mass of the piston and weights} \\ G_l &= \text{Gravity at location in cm/s}^2 \\ G_s &= \text{Standard gravity 980.665 cm/s}^2 \end{aligned}$$

The effective area of the piston cylinder unit (PCU) has been calibrated and the results reported at 20 °C. As the temperature varies, so will the effective area of the PCU. This change is directly dependent on the thermal coefficient of expansion for the piston and cylinder. The temperature throughout the calibration should remain stable, within 1 °C per hour. The pressure standard and instrument under test should be in the calibration location for at least 4 hours, ideally 24 hours to thermally stabilise. The temperature of the PCU should be known to 0.25 °C. Correct for changes in the effective area as follows:-

$$A_T = A (1 + \lambda (T - 20))$$

where

$$A_T = \text{Effective area at temperature } T$$

$$A = \text{Effective area at } 20 \text{ }^\circ\text{C}$$

$$\lambda = \text{Combined thermal coefficient of expansion of the piston and cylinder}$$

$$T = \text{Temperature of the piston and cylinder unit}$$

### 2.3 Air Density

Mass by definition is taken in a vacuum. When the weight masses are used (gauge mode), they are used in atmosphere and therefore air is displaced. The mass of the object will reduce by the amount equal to the mass of the fluid (air) displaced as per Archimedes principal. Therefore the downward force needs to be corrected for the air buoyancy effect as follows:-

$$F_c = F (1 - \rho_a/\rho_m)$$

where

$$F_c = \text{Air buoyancy corrected force}$$

$$F = \text{Uncompensated force}$$

$$\rho_a = \text{Air density nominally } 0.0012 \text{ g/cm}^3 *$$

$$\rho_m = \text{Mass density } 8 \text{ g/cm}^3$$

The mass values reported represent the mass of a hypothetical weight of density 8 g/cm<sup>3</sup> which would balance that weight in air of density 0.0012 g/cm<sup>3</sup> at 20 °C

\* For air density values see Appendix A.

### 2.4 Head of Fluid

The pressure datum line is the top surface of the triangle. The height of the reference level of the instrument under test relative to this datum line should be corrected for due to the head of fluid as follows:-

$$H = h \rho_f (1 - \rho_a/\rho_f)(G_l/G_s)$$

where

$$H = \text{Head pressure}$$

$$h = \text{Vertical distance between the top face of the triangular base and the instrument under test}$$

$$\rho_f = \text{Density of the pressure medium}$$

$$\rho_a = \text{Air density}$$

$$G_l = \text{Gravity at location in cm/s}^2$$

$$G_s = \text{Standard gravity } 980.665 \text{ cm/s}^2$$

As pressure is applied, both the piston and cylinder reversably distort. This distortion alters the effective area of the PCU. The distortion is assumed to be linear and has been calculated by cross floating the PCU at various pressures across its operating range, and applying the best straight line fit (least square) to the results. Correct for the change in area with pressure as follows:-

$$A = A_o (1 + aP)$$

where

$$\begin{aligned} A &= \text{Effective area at pressure } P \\ A_o &= \text{Effective area of the piston at zero pressure} \\ a &= \text{Pressure deformation coefficient} \\ P &= \text{Operating pressure} \end{aligned}$$

## 2.6 Piston Float Height

The piston and cylinder unit has been calibrated with reference to the bottom face of the piston at its mid operating position. Therefore during calibration at the point of taking the reading the piston should be at its mid operating position. Variation from the mid operating position will result in both a head of fluid error and the possibility of a slight change in the effective area due to the geometry of the piston. Therefore for the best result the piston should be spinning at its mid operating position at the time of taking the calibration reading.

## 2.7 Verticality

The piston must be vertical otherwise a proportion of the downward force acting on the piston will be transferred to the wall of the cylinder. The force is proportional to the cosine of the angle of the piston relative to the vertical, and can be corrected as follows:-

$$F_v = F \times \cos\theta$$

where

$$\begin{aligned} F_v &= \text{Corrected force} \\ F &= \text{Vertical force} \\ \cos\theta &= \text{Angle between the piston axis and vertical} \end{aligned}$$

To avoid the above always ensure that the triangular base has been levelled so that the piston is vertical. Each foot has a locking nut to ensure that no changes occur during calibration.

## 2.8 Fluid Buoyancy and Loading

Where the part of the piston that is submerged in the operating medium deviates from its working area, then the volume of this deviation needs to be corrected for as follows:-

$$M_c = M - V_p f (1 - \rho_a / \rho_f)$$

where

$$\begin{aligned} M_c &= \text{Mass compensated for fluid buoyancy and fluid loading effect} \\ M &= \text{Mass of the piston and weights} \\ V &= \text{The net volume difference} \\ \rho_f &= \text{Density of the pressure medium} \\ \rho_a &= \text{Air density} \end{aligned}$$

The operating medium passes between the piston and cylinder to atmosphere. At the interface between the operating medium and atmosphere there is an additional downward force which is generated by the surface tension of the operating medium and is compensated for as follows:-

$$F_c = F + SC$$

where

$F_c$  = Force compensated for surface tension

$F$  = Downward force

$S$  = Surface tension of the pressure medium

$C$  = Circumference of the piston

## 2.10 Thermal Stability

The pressure system is a closed system. As the pressure is increased to float the piston, heat is generated. As this heat dissipates, the piston will fall more quickly. Therefore sufficient time, typically 5 minutes, must be allowed for the system to thermally stabilise. The time required will vary with the speed and magnitude of the pressure change. The effect is inverted for decreasing pressures.

Section 2 outlined the major effects that influence the pressure of the pressure standard. The following section covers worked examples.

A full suite of PC based software is available to carry out all the calculations, see Section 10.1, Page 26.

All calculations should be made to at least six significant figures.

### 3.1 Pressure Calculation

Combining all the influences mentioned in Section 2, we get the following equation:

$$P = K \frac{(M + \Sigma M)(1 - \rho_a / \rho_m)(G_l / G_S) \cos \theta - V \rho_f (1 - \rho_a / \rho_f)(G_l / G_S) \cos \theta + S_c - h \rho_f (1 - \rho_a / \rho_f)(G_l / G_S) + R_P - F}{A (1 + a_p + \lambda (T - 20))} \quad (1)$$

where

P = Pressure

K = Pressure unit conversion factor from Kgf/cm<sup>2</sup>:

For: Kgf/cm <sup>2</sup>	1
bar	0.980665
psi	14.22334

$\rho_a$  = Density ambient air, g/cm<sup>3</sup> x 10<sup>-3</sup>

$\rho_m$  = Density weights, piston and weight carrier, g/cm<sup>3</sup> x 10<sup>-3</sup>

M = Mass of the piston and weight carrier, Kg

$\Sigma M$  = Sum of the weight masses used, Kg

$G_l$  = Local acceleration due to gravity, cm/s<sup>2</sup>

$G_S$  = Standard gravity 980.665 cm/s<sup>2</sup>

$\theta$  = Angle in degrees between piston axis and vertical. Level the instrument so this is zero.

V = Net buoyancy volume of the piston cm<sup>3</sup>

$\rho_f$  = Density of the pressure medium, g/cm<sup>3</sup> x 10<sup>-3</sup>

S = Surface tension of the pressure medium, Kgf/cm x 10<sup>-6</sup>

c = Circumference of the piston, cm

h = Vertical distance between the reference level and the instrument under test, cm. Heights above reference level positive, heights below negative.

- RP = Reference pressure in Kgf/cm<sup>2</sup>. Zero for gauge mode and as measured for absolute mode.
- F = Friction in the downward movement of the piston. This is only theoretical, provided the piston and cylinder are clean and rotating freely this will tend to zero.
- A = Effective area of the PCU at zero pressure, cm<sup>2</sup> at 20 °C
- a = Piston pressure deformation coefficient, per MPa
- p = Nominal pressure, MPa
- T = Temperature of the piston and cylinder unit, °C
- λ = Combined thermal coefficient of expansion of the piston and cylinder, ppm per °C x 10<sup>-6</sup>

We can simplify equation (1) as follows:-

$$\begin{aligned} \cos\theta &\cong 0 \\ RP &= 0 \\ F &\cong 0 \end{aligned}$$

$$GA = \text{Combined gravity and air density correction} \\ (1 - \rho_a/\rho_m)(G_l/G_s)$$

$$C = \text{Buoyancy and surface tension constant} \\ V_{pf} (1 - \rho_a/\rho_f)(G_l/G_s) - S_c$$

$$H = \text{Head of fluid} \\ h_{pf} (1 - \rho_a/\rho_f)(G_l/G_s)$$

The above can be treated as constants throughout the calibration. APT is pressure dependent and requires recalculating at each pressure point.

$$\begin{aligned} \text{APT} &= \text{Effective area at 20 °C and pressure p} \\ &A (1 + a_p + \lambda (T - 20)) \end{aligned}$$

therefore

$$P = K \frac{(M + \Sigma M) GA - C - H}{\text{APT}} \quad (2)$$

Calculate the pressure using equation (2)



## Example A

$$K = 0.980665 \text{ (for bar)}$$

$$\rho_a = 0.0012 \text{ g/cm}^3 \times 10^{-3}$$

$$\rho_m = 8 \text{ g/cm}^3 \times 10^{-3}$$

$$M = 0.410946 \text{ Kg}$$

$$\Sigma M = 16.43603 \text{ Kg}$$

$$G_I = 981.196 \text{ cm/s}^2$$

$$G_S = 980.665 \text{ cm/s}^2$$

$$V = 0.277 \text{ cm}^3$$

$$\rho_f = 0.865 \text{ g/cm}^3 \times 10^{-3}$$

$$S = 30 \times 10^{-6} \text{ Kgf/cm}$$

$$c = 1.006227 \text{ cm (Calculated from area where } c = \Pi D, \text{ Area} = \Pi D^2/4)$$

$$h = -2.4 \text{ cm} \times 10^{-3}$$

$$A = 0.0805716 \text{ cm}^2$$

$$a = 0.000002335 \text{ per MPa}$$

$$p = 20.5 \text{ MPa}$$

$$T = 20 \text{ }^\circ\text{C}$$

$$\lambda = 16.5 \times 10^{-6}$$

therefore

$$\begin{aligned} GA &= (1 - 0.0012 \times 10^{-3}/8 \times 10^{-3})(981.196/980.665) \\ &= 1.00003914 \end{aligned}$$

$$\begin{aligned} C &= 0.277 \times 0.865 \times 10^{-3} (1 - 0.0012 \times 10^{-3}/0.865 \times 10^{-3})(981.196/980.665) - 30 \times 10^{-6} \times 1.006227 \\ &= 0.0002092 \end{aligned}$$

$$\begin{aligned} H &= -2.4 \times 0.865 \times 10^{-3} (1 - 0.0012 \times 10^{-3}/0.865 \times 10^{-3})(981.196/980.665) \\ &= -0.0020742 \end{aligned}$$

$$\begin{aligned} APT &= 0.0805716 (1 - 2.335 \times 10^{-6} \times 20.5) \\ &= 0.080575 \end{aligned}$$

Using equation 2

$$\begin{aligned} \text{Pressure} &= \frac{0.980665 \times (0.410946 + 16.43603) \times 1.0003914 - 0.0002092 + 0.0020742}{0.0805755} \\ &= 205.1202 \text{ bar} \end{aligned}$$

### 3.2 Mass Calculation

To calculate the mass required to generate a specific pressure P, use equation (3).

$$\Sigma M = \frac{P \times APT + K \times (c + H \times APT)}{K \times GA} - M \quad (3)$$

#### Example B

Using the same data as in example A we get, the mass required to generate a pressure of 205.1202 bar would be:

$$\begin{aligned} \Sigma M &= \frac{205.1202 \times 0.0805755 + 0.980665(0.0002092 - 0.0020742 \times 0.0805755)}{0.980665 \times 1.0003914} - 0.410946 \\ &= 16.43603 \text{ Kg} \end{aligned}$$

Nominal Weight Mass Grams	NOMINAL		PRESSURE	
	PCU 21, 26, 31	PCU 22	PCU 23, 24, 32	PCU 25
bar				
41.12	0.05	0.2	0.5	1
2056.6	0.25	1	2.5	5
411.2	0.5	2	5	10
2056	2.5	10	25	50
4112	5.0	20	50	100
psi				
56.6	1	4	10	20
283	5	20	50	100
566	10	40	100	200
2830	50	200	500	1000
5660	100	400	1000	2000
kgf/cm <sup>2</sup>				
40.3	0.05	0.2	0.5	1
201.5	0.25	1	2.5	5
403	0.5	2	5	10
2015	2.5	10	25	50
4030	5.0	20	50	100

- Calibrated weight set in wooden cases
- Certificate of Piston Effective Area
- Certificate of Weight Masses
- PCU's and weights as stated on System Details
- Triangular base
- Ram screw to generate pressure
- Reservoir
- Reservoir valve
- Levelling feel with locking nut
- Foot locators
- \* Range of adaptors to mount various PCU's
- Spirit level
- All necessary piping
- Take off port for external connection
- Piston weight carrier and dish to load trim masses
- Test station and adaptors 1/8", 1/4", 3/8", 1/2" BSP or NPT (please specify)
- Spare Seals
- Cotton Gloves
- Piston Lubricating Oil - Specification: Our reference ST55
  - Oil supplied - Shell Tellus 22
  - Compatible oils - Esso Nuto H22
  - Mobil Velocite No.10

\* To assist in head corrections, the adaptor has a horizontal groove which nominally aligns to the bottom of the piston in its mid operating position. This reference groove is based on the standard dimension of a PCU.

5.1

**ADAPTORS HYDRAULIC**

**REFERENCE**

**MANUFACTURER**

OIL 1

PRESSUREMENTS  
PCU 21, 26 & 31

OIL 2

PRESSUREMENTS  
PCU 22, 23 ,24, 25 & 32

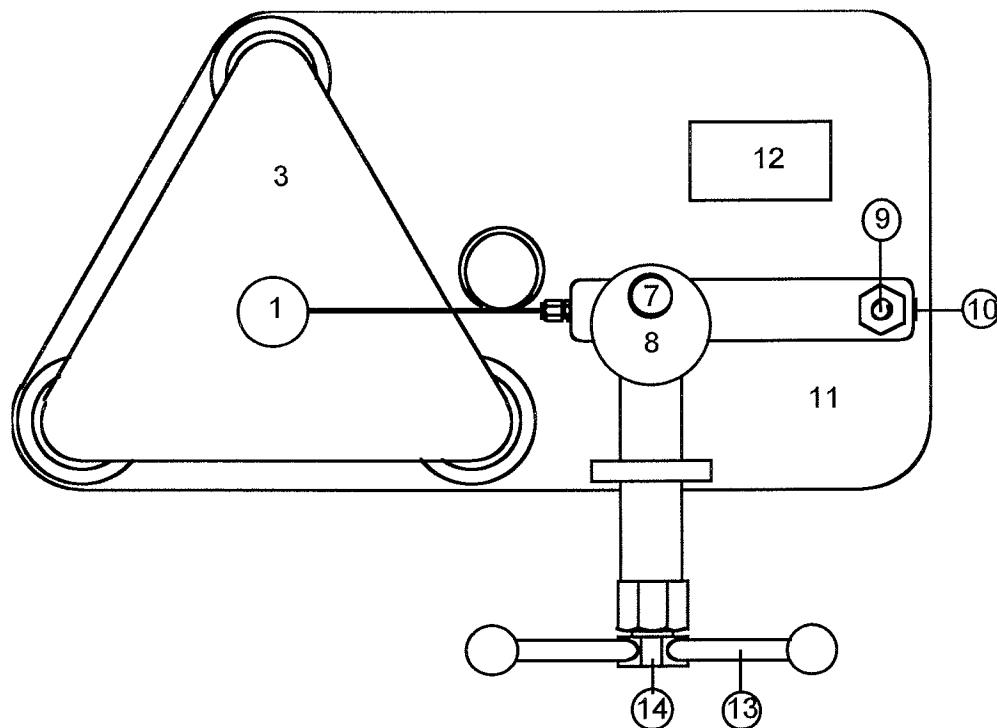

FIGURE 1

- |   |                 |    |                 |
|---|-----------------|----|-----------------|
| 1 | PISTON          | 9  | TEST STATION    |
| 3 | BASE            | 10 | ACCESSORY PLUG  |
| 4 | LOCKING RING    | 11 | MOUNTING PLATE  |
| 5 | ADJUSTABLE FOOT | 12 | LABEL           |
| 7 | VALVE           | 13 | SPOKE           |
| 8 | RESERVOIR       | 14 | CAPSTAN HUB     |
|   |                 | 15 | CONNECTION PIPE |

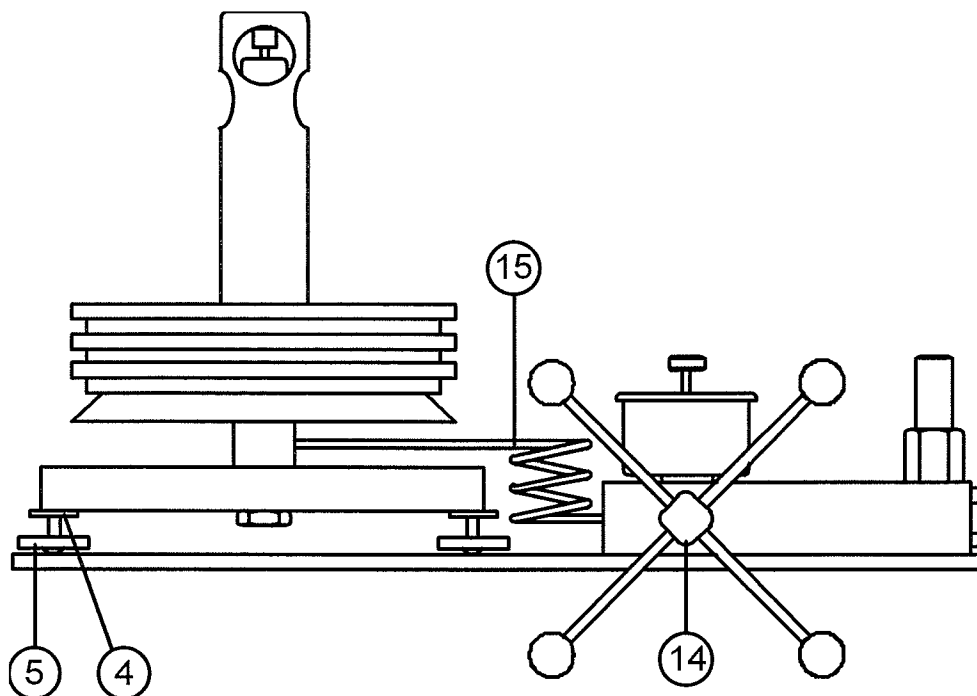

FIGURE 2

- 6.1 The pressure standard should be set up in a draught free, thermally stable room, free from excessive personnel movement.
- 6.2 The bench for the pressure standard should be sufficiently rigid to avoid deflection and be located on a stable floor.
- 6.3 Carefully unpack the instrument and associated components.
- 6.4 Place the Mounting Plate (11) and Triangular Bases (3) on the bench as shown in Figures 1 & 2, Page12.  
Fit Spokes (13) to Capstan Hub (14).
- 6.5 Connect Connection Pipe (15), ensure connections are tight.
- 6.6 Shut Reservoir Valve (7) by turning clockwise.
- 6.7 Fill Reservoir (8) with the correct operating fluid.
- 6.8 Plug Test Station (9) using the plug and adaptor supplied.
- 6.9 Screw appropriate adaptor into Piston Port (1) (see Section 5.1).  
Fit appropriate bonded seal.
- 6.10 Place thumb over the bonded seal, open Valve (7) by turning anti-clockwise.  
Still keeping thumb on the bonded seal, screw Capstan (14) fully out.  
Shut Valve (7). Remove thumb from bonded seal. Screw capstan in until the oil appears at the top of the bonded seal. If oil does not appear after the capstan is fully screwed in, repeat this process.
- 6.11 Carefully unpack the PCU. Clean and assemble as per Instructions 8.2 to 8.5.
- 6.12 Place the weight set to the left of the triangular base.
- 6.13 Level the triangular base to the fixed spirit level. Once the base is level lock the foot positions, use Locking Ring (4)

## 7.0 PRESSURE MEASURED CALIBRATION

Refer to Figures 1 & 2, Page 12.

Ensure the correct PCU is fitted, to cover the pressure range of the instrument to be tested.

### 7.1 Fit instrument to be tested to Test Station (9):-

Screw the appropriate Test Station Adaptor fully onto the instrument to be tested. Screw assembly down ANTI-CLOCKWISE onto the Test Station.

**Note:** The internal thread on the lower half of the Adaptor is LEFT-HANDED. Ensure that the bottom face of the instrument to be tested contacts the seal on the Test Station.

To adjust position to face forward. Hold the Adaptor and unscrew the instrument to be tested ANTI-CLOCKWISE so that it faces forward. Hold the instrument to be tested steady whilst turning the Adaptor ANTI-CLOCKWISE until it pulls down onto the seal.

Tighten fully to ensure a good seal.

**IMPORTANT:** ENSURE THAT ANY INSTRUMENT FITTED TO THE TEST STATION IS INTERNALLY CLEAN.

**Note:** The pressure datum line is the top face of the triangular base (3). Ensure any vertical height difference between this datum line and the instrument under test has been measured and included in the calculation.

### 7.2 Open Valve (7) one turn anti-clockwise and screw Capstan (14) fully in.

### 7.3 \* Close Valve and screw Capstan FULLY OUT.

### 7.4 Open Valve and screw Capstan FULLY IN.

**Note:** During this operation bubbles may appear in the Reservoir (8), as trapped air is expelled. For large volume instruments repeat steps 7.3 and 7.4 until no further bubbles appear.

### 7.5 With Valve open, screw Capstan FULLY OUT and close Valve.

**\*WARNING:**

Screwing the Capstan (14) out with Valve (7) closed will generate approximately 0.5 bar/15 inHg vacuum. If the instrument under test is vacuum sensitive, leave Valve open during operation 7.3.

- 7.6 Select the required weights and stack onto the Piston Weight Carrier (1 ). The pressure measured is the sum of the weights plus the Piston Weight Carrier. See Calculations, Section 3. If a specific pressure is required see Section 3.2 to calculate the weights required.
- 7.7 If a trim mass dish is included in the weight carrier mass, then ensure that it is mounted on the top of the carrier tube when all readings are being taken. For utmost accuracy record the temperature of the PCU.
- 7.8 To generate pressure screw the Capstan (14) in. When the Piston rises, ensure the bottom face of the carrier ring is aligned to the mid operating position of the piston. See Figure 3.

**Note:** To establish the mid operating position of the piston, record the position of the bottom face of the carrier ring when the piston is fully down. Pressurise by screwing in the capstan until the piston is against its top stop. Again record the carrier position. The mid operating position of the piston will be half way between these two points.

- 7.9 Rotate the weight stack clockwise.

**Note:** If the PCU uses an overhang weight carrier, remove the trim mass dish and rotate the weight stack by evenly turning the top of the overhang carrier tube. The rotation should be typically between 30 and 90 RPM. Replace trim mass dish.

**DO NOT** rotate by pushing the weights as this will cause the weight stack to oscillate.

- 7.10 Observe the reading of the instrument under test.
- 7.11 For the next higher calibration point, repeat 7.6 above.
- 7.12 To measure reducing pressures, remove the necessary weights, and screw the Capstan out so that the weight stack floats at the correct height, then rotate clockwise.
- 7.13 Depressurise by screwing Capstan FULLY OUT.  
**NEVER RELEASE SYSTEM PRESSURE WITHOUT SCREWING CAPSTAN FULLY OUT FIRST.**
- 7.14 Remove weight stack.

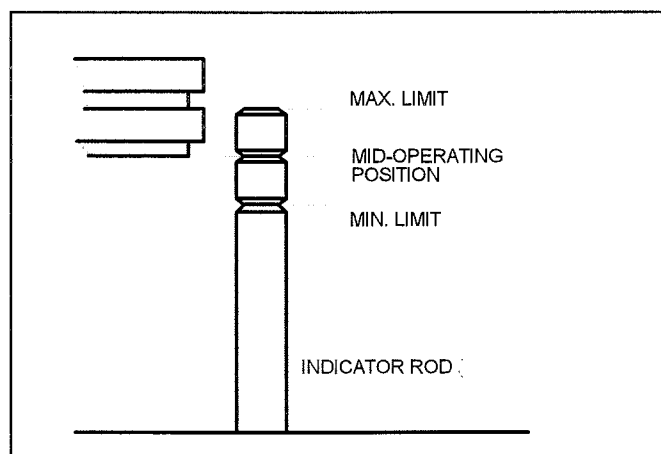

FIGURE 3



## 80 PISTON CARE

The Piston and Cylinder Unit (PCU) is the most critical and sensitive part of the Pressure Standard. To maintain accuracy, the Piston must always slide freely in the Cylinder

**Note:** Ensure system is depressurised before attempting Piston removal, by turning the Capstan FULLY out, and SLOWLY opening Reservoir Valve.

### 8.1 PISTON REMOVAL

Refer to Figures 4 & 5, Page 19.

#### 8.1.1 PISTON REMOVAL - PCU22, 23, 24, 25, 32

Lift off Weight Carrier Assembly (8) and unscrew Piston Nut (5)

Use dowel hole if nut is tight.

Remove assembly.

Gently pull off Piston Cap (4 or 11). DO NOT PULL IN SUCH A WAY THAT THE PISTON CAN BEND.

The Piston and Cylinder can now be removed and separated. Remove and clean the 'O' ring in the cylinder counter bore (not applicable to PCU22)

#### 8.1.2 PISTON REMOVAL - PCU21, 26, 31

Refer to Figure 6, Page 20.

Lift up Table Weight Carrier (14) and tap sharply downwards onto top of Cylinder.

Remove Table Weight Carrier.

Unscrew Cylinder (13), use dowel hole in side of Cylinder if tight.

The Piston and Cylinder can now be removed, and separated.

### 8.2 PISTON CLEANING - ALL PCU's

IMPORTANT:

NEVER TOUCH THE WORKING AREA OF A CLEAN PISTON WITH BARE FINGERS - THE NATURAL OIL IN YOUR SKIN CAN CAUSE THE PISTON AND CYLINDER ASSEMBLY TO STICK

Use 'non-fluffing', non-abrasive, lint-free tissue or absorbent cloth.

Hold the Piston by the larger 'head' end, and rub the tissue back and forth along its length.

To remove all traces of contamination, the Piston must be immersed in a non-filming solvent such as Trichloroethylene, Isopropanol or Acetone.

Using a NEW tissue, clean the Piston as before, pressing hard between thumb and forefinger along the Piston's length.

Place Piston carefully on a NEW tissue where it will not become dirty or damaged whilst the Cylinder is cleaned.

### 8.3 CYLINDER CLEANING - ALL PCU's

Roll a tissue into a tapered rod of appropriate size. Force the tissue through the Cylinder bore by rotating. Ensure the tissue is tight so that dirt is removed. Repeat, inserting a NEW tissue from the opposite end.

To remove all traces of contamination the Cylinder must be immersed in a suitable solvent.

After removal from the solvent, using a NEW tissue, repeat the cleaning process above.

## 8.4 PISTON RE-ASSEMBLY

### GENERAL:

The Piston must be carefully introduced into its Cylinder.

If both parts are aligned and correctly cleaned, the Piston will slide freely into the Cylinder.

**NEVER FORCE THE PISTON INTO ITS CYLINDER OR DAMAGE MAY RESULT.**

If resistance is felt, then re-clean either Piston, Cylinder or both.

If, after repeated cleaning, the Piston still will not slide freely within the Cylinder, then permanent damage may have occurred, in which case the complete assembly will need to be replaced or returned for evaluation.

### 8.4.1 PISTON RE-ASSEMBLY - PCU22, 23, 24, 25, 32

Ensure that 'O' Ring is correctly re-fitted into counter-bore in Cylinder (Not applicable to PCU22).

Hold Piston by larger, 'head' end, dip the other end into a container of clean operating fluid and transfer to the bore in the underside of the Cylinder.

Allow the fluid to run through the bore. Repeat this procedure 2 or 3 times to ensure an even film of clean fluid exists in the bore.

Carefully introduce the end of the Piston into the larger diameter end of the Cylinder and push gently through.

**NEVER FORCE THE PISTON INTO ITS CYLINDER OR DAMAGE MAY RESULT.**

If resistance is felt, introduce more fluid. If resistance continues, then re-clean either Piston, Cylinder or both.

When the Piston slides freely in the Cylinder, insert Piston/Cylinder assembly into Piston Nut such that it locates as shown. Replace Piston Cap, ensuring that it is fully home.

### 8.4.2 PISTON RE-ASSEMBLY - PCU21, 26, 31

Hold Piston by larger, 'head' end, dip the other end into a container of clean operating fluid and transfer to the bore in the threaded end of the Cylinder.

Allow the fluid to run through the bore. Repeat this procedure 2 or 3 times to ensure an even film of clean fluid exists in the bore.

Carefully introduce the end of the Piston into the threaded end of the Cylinder and push gently through.

When the piston slides freely in the Cylinder

**NEVER FORCE THE PISTON INTO ITS CYLINDER OR DAMAGE MAY RESULT.**

If resistance is felt, introduce more fluid. If resistance continues, then re-clean either Piston, Cylinder or both.

When the Piston slides freely in the Cylinder, stand the Piston/Cylinder assembly upright on a clean, hard, stable surface.

Ensure Table Weight Carrier is clean, especially the central mounting hole, and place on the tapered end of the Piston. Tap lightly using the palm of the hand to locate on the taper.

## 8.5 REFITTING - ALL PCU's

Screw assembly onto Adaptor, ensuring that the Bonded Seal is clean and the fluid is adjacent to the top of the seal. Do not over-tighten.

**8.6 PISTON SPIN/SENSITIVITY**

IF PISTON IS NOT FREE, DO NOT ROTATE AS DAMAGE MAY OCCUR, DISMANTLE AND CLEAN.

When floating the Piston and Weight Carrier alone, it should rotate freely, and slowly come to a smooth halt. If the rotation halts abruptly, then clean the Piston as described above.

Open Reservoir Valve. Lift off Weight Carrier Assembly. Holding the Piston cap, lift gently up and down. The Piston should slide freely within its Cylinder, if any resistance or a 'gritty' sensation is detected, then it must be cleaned as described above.

If spin/sensitivity of a cleaned Piston deteriorates quickly then it is likely that the Deadweight Tester system is contaminated and must be completely dismantled, cleaned and rebuilt.

**8.7 PISTON INCREASED FALL RATE**

The Piston will always drop slowly due to a small leak between the Piston and Cylinder. However, after re-assembly some air may be trapped under the PCU. The air passing between the piston and cylinder will cause a quicker fall rate. If this is occurring, air bubbles should appear in the fluid where the piston exits the cylinder. Keep the piston spinning and floating to purge the air until the fall rate stabilises.

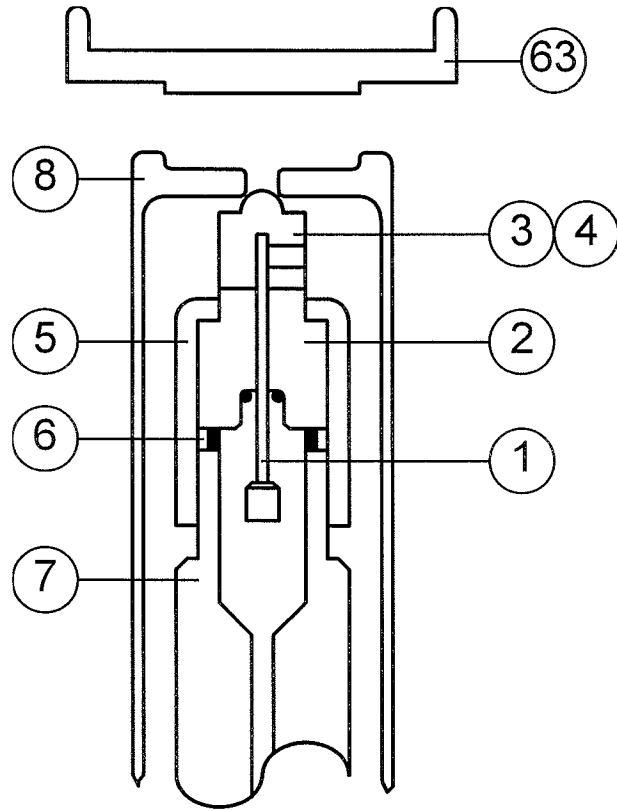

PCU 23, 24, 25, 32

FIGURE 4

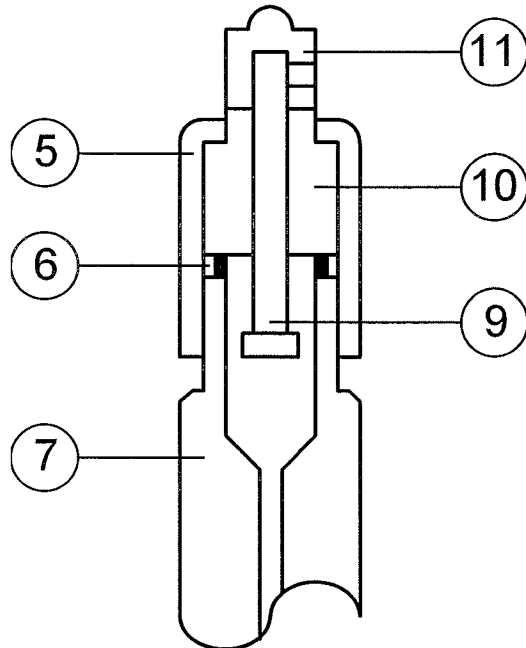

PCU 22

FIGURE 5

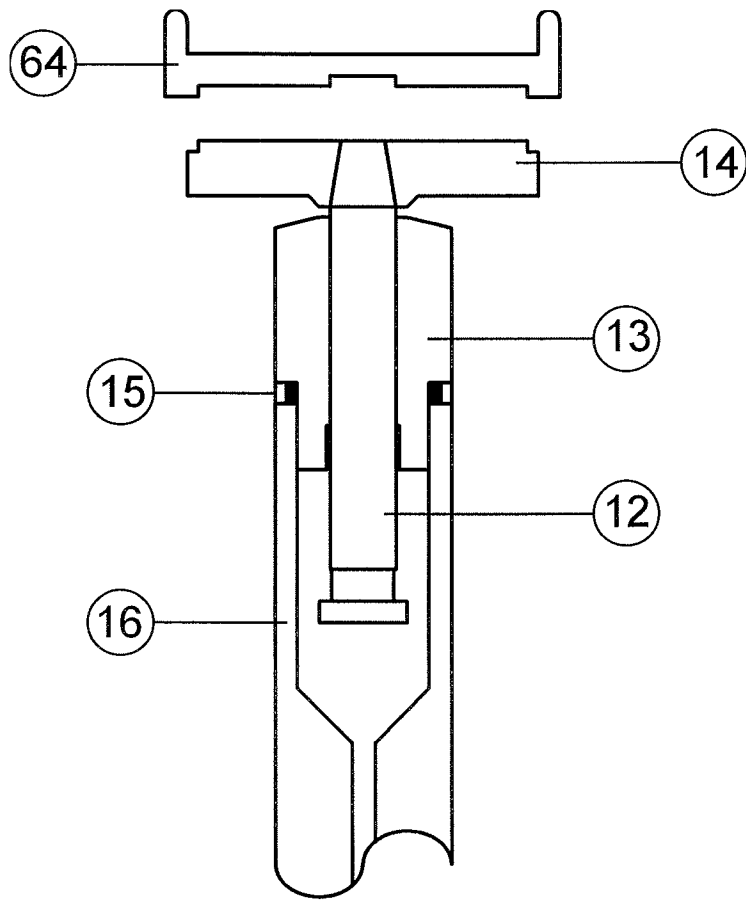

PCU 21, 26, 31

FIGURE 6

## 9.0 GENERAL ARRANGEMENT DRAWINGS &amp; PARTS LIST

ITEM	PART	DESCRIPTION
1	D4101	PISTON
2	D4102	CYLINDER
3	B1801	'O' RING
4	D4107	PISTON CAP
5	D7011	PISTON NUT
6	B1902	BONDED SEAL
7	D7013	ADAPTOR
8	D7002	OVERHANG WEIGHT CARRIER
9	D4001	PISTON
10	D4002	CYLINDER
11	D4003	PISTON CAP
12	D4116	PISTON
13	D4117	CYLINDER
14	D7029	TABLE WEIGHT CARRIER
15	B1802	BONDED SEAL
16	D7012	ADAPTOR
17	D7044	PLUG
18	D7010	BEARING RING
19	D7008	COLUMN (LEFT PORT)
20	D7009	COLUMN (RIGHT PORT)
21	D7001	BASE PLATE
22	B1807	LOCKNUT
23	D1048	FOOT
24	D1046W	STUD
25	D7026	LOCK SCREW
26	D7018	FOOT LOCATOR
27	B2906	'O' RING
28	B4723	PIPE COUPLING
29	D4724	PIPE
30	B7022	'O' RING
31	D7032	MANIFOLD
32	D1205	RESERVOIR VALVE BODY
33	B1025	'O' RING
34	B1033	BONDED SEAL
35	B1206	LOCKNUT
36	D1203	VALVE STEM
37	D1207	VALVE CAP
38	B1213	SPRING
39	D1208	RESERVOIR
40	D1209	RESERVOIR COVER
41	D2811	RAMBLER
42	B2809	'O' RING
43	B2810	ANTI-EXTRUSION RING
44	B1022	BALL

## 9.0 GENERAL ARRANGEMENT DRAWINGS &amp; PARTS LIST (CONTINUED)

ITEM	PART	DESCRIPTION
45	D2808	BARREL
46	B1054	'O' RING
47	B1023	LOCKNUT
48	D2812	RAM SCREW / NUT
49	D2814	COLLAR
50	D1133	HUB
51	B1021	KNOB
52	D1020	SPOKE
53	D1019	UNION NUT
54	D7041	BARREL CLAMP
55	B7042	SCREW
56	D7045	MOUNTING PLATE
57	D3605	TEST STATION
58	B3614	'O' RING
59	B3606	'O' RING
60	D5519	1/8 BSP PLUG
61	D1018/2	1/4 BSP ADAPTOR
62	B2428	1/4 BSP PLUG
63	D7006	HP TRIM MASS DISH
64	D7031	LP TRIM MASS DISH

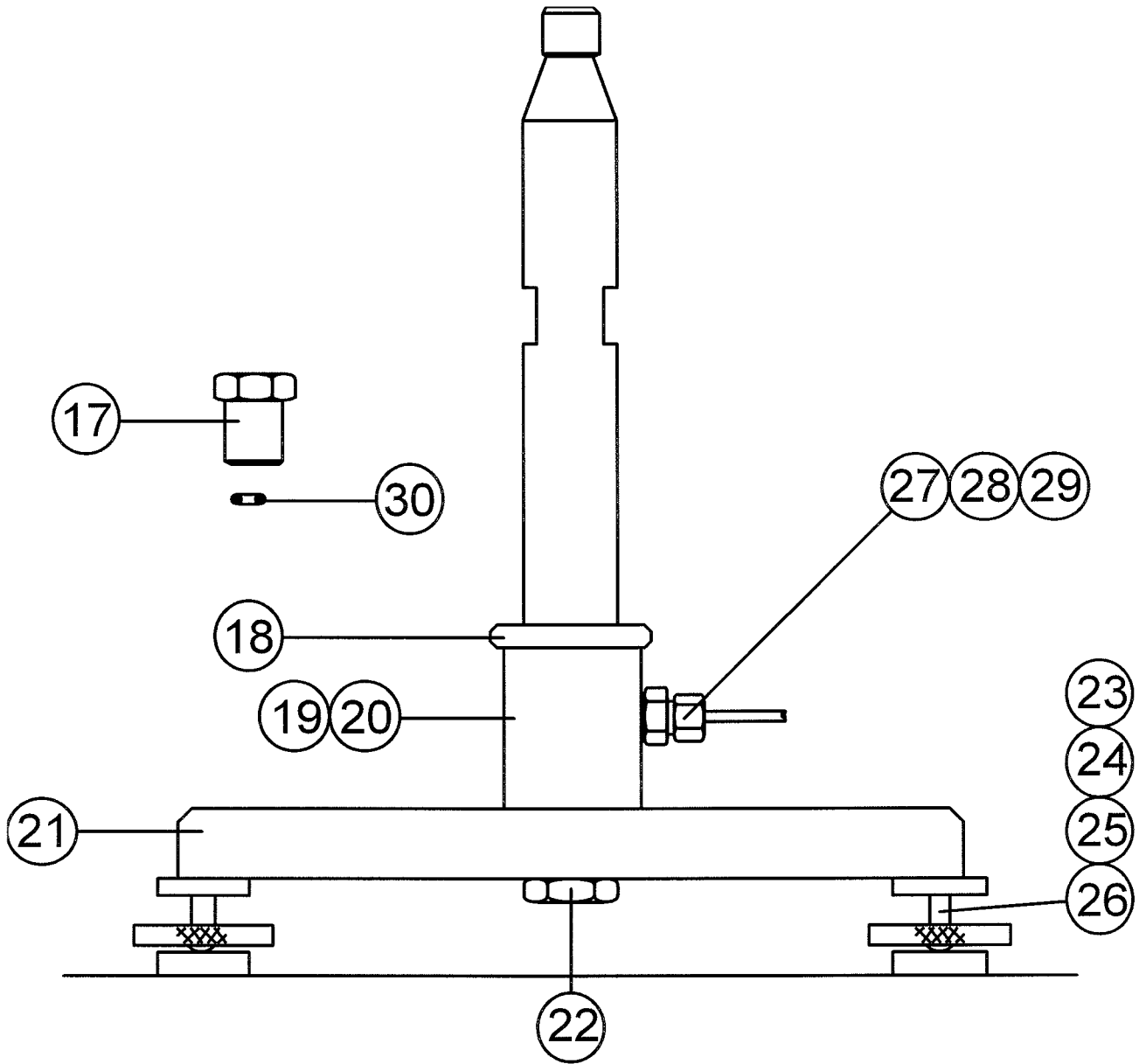



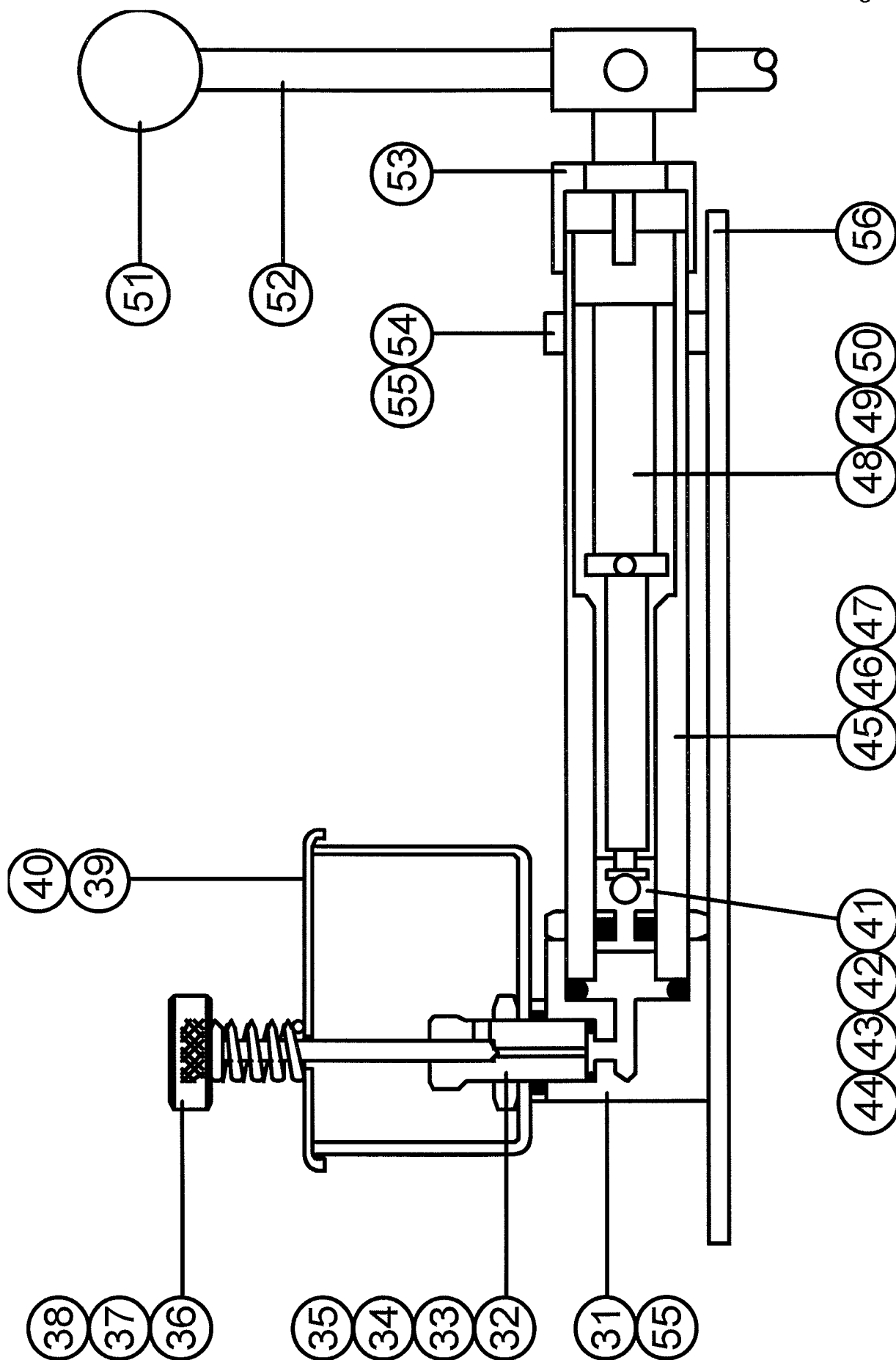

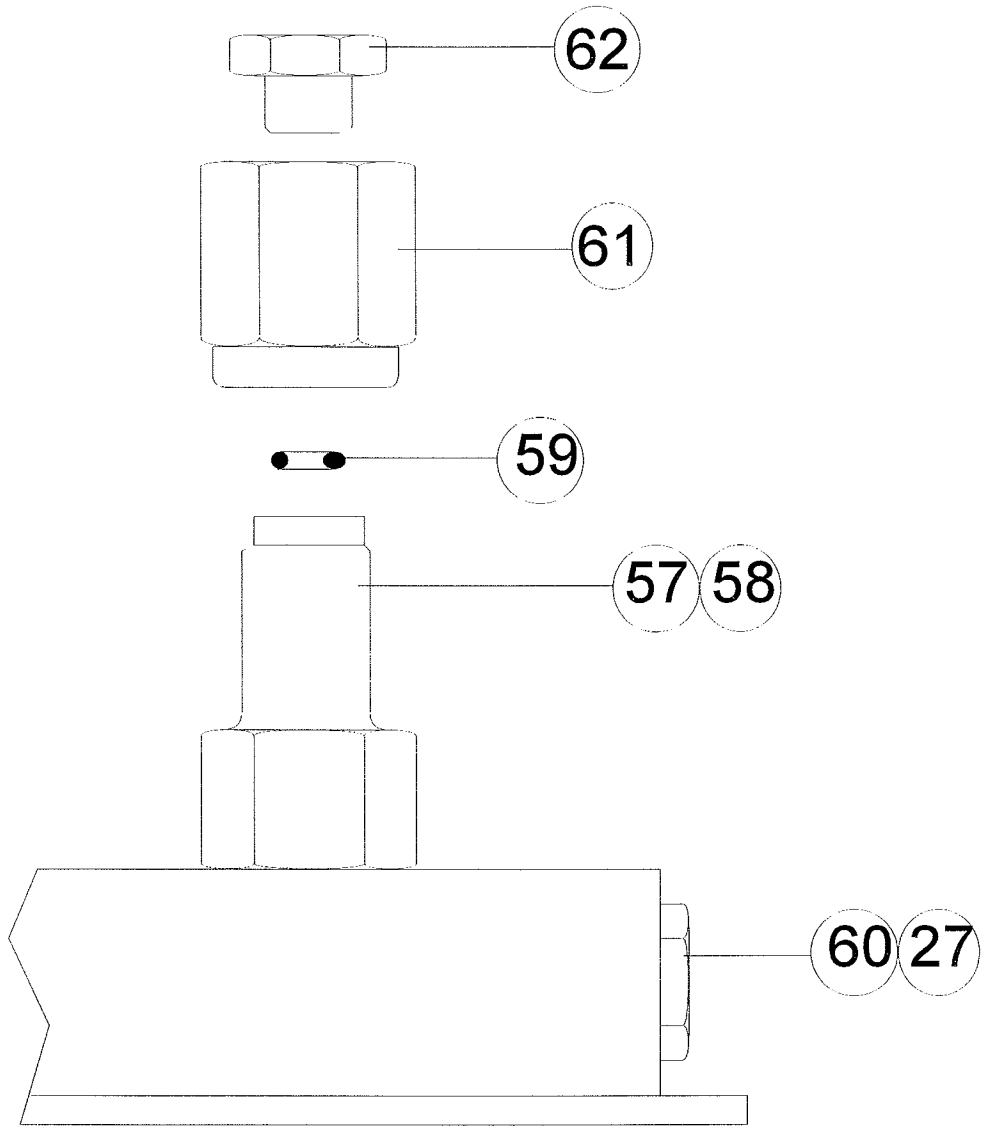

## 10.0 ANCILLARY EQUIPMENT

If you require further information on any of the following equipment, please contact your local agent.

### 10.1 S700M CALIBRATION SOFTWARE

A full suite of dedicated software run under DOS is available. All software is programmed with the pressure standards details, and is fully tested.

- **Software Program S710:** This program calculates the Effective Area of the target piston cylinder unit, cross-floated in Model P7110, P7120, P7130, P7200 and/or P7300.
- **Software Program S720:** This program takes the Effective Area of either one or two piston cylinder units and calculates the weight masses required to generate given pressures. It includes the Optimum Mean Mass value and the deviation factor from ideal.
- **Software Program S730:** This program calculates the Pressure Measured given the target piston cylinder unit effective area and the actual weight masses.
- **Software Program S740:** This program calculates the weights required to generate a specific pressure.
- **Software Program S750:** This program calculates the pressure given the weights that have been used.

#### Calibration Application

S710 & S720	-	Deadweight Tester Area and Mass calibration where the weight masses are adjusted
S710 & S730	-	Deadweight Tester Area and Mass calibration
S740 & S750	-	Pressure Measured calibration

All the above programs take into account where applicable the following:-

- Gravity
- Temperature
- Air Density
- Actual mass
- Density of the masses
- Head of oil
- Density of oil
- Combined surface tension and fluid loading/buoyancy
- Piston effective area
- Piston distortion coefficient.

The software has been developed as a flexible working tool, where the operator can amend, update all the base data. Passwords are used to ensure only authorised personnel can access the base data. Results are in a certificate format which can be output to a screen, printer and to file. A comprehensive manual is supplied with all software. Customised software is available, i.e. absolute pressure, specific certificate format, output to database etc.

Hardware Requirements:-

- Run on an IBM compatible PC
- Supplied on 3.5" 1.44 Mb diskettes
- 3 Mb hard disk free space required
- Minimum 1 Mb ram, recommend 2 Mb or more
- Vga monitor or better (preferably colour)
- Require DOS version 3.2 or later
- Can run under Windows and Windows '95

## 10.2 TEMPERATURE SENSOR

Thermister temperature probes can be supplied. Location is adjacent to the piston cylinder unit. The proximity of this sensor coupled with its accuracy allows for the effect of temperature on the PCU to be calculated to an uncertainty of better than 2 ppm.

For pressure ranges up to and including 35 bar, 500 psi, the probe is placed on the outside of the cylinder. For other PCU's the probe is placed approximately 5 mm below the cylinder on the mounting adaptor.

If the pressure standard is used for calibrating Deadweight Testers, then a second temperature probe can be supplied to be placed on the outside of the cylinder of the target PCU.

The thermister temperature probes are supplied with a battery powered display, either analogue needle or digital. Accuracy typically 0.03 °C. The digital display can be supplied with an optional RS232 port.

## 10.3 MONITORING THE PISTON POSITION AND FALL RATE

The piston position and fall rate can be monitored:

Manually: - Visually referencing the bottom face of the first weight against a vertically mounted ruler

To ensure minimum parallax errors:-

- (a) the rule is mounted close to the edge of the weight
- (b) the bottom weight has an angled edge
- (c) the underside of the weight has a grooved shadow line

Automatically: - Non contacting displacement sensors can be supplied. This option is recommended for the most precise work. Eddy current sensors are used to reduce the influence of different materials and localised movement.

The system is supplied with either one sensor for the pressure standard or two sensors for 'cross float' systems. Full software is supplied to allow piston position and displacement to be displayed in real time on a PC, VDU. The software runs under DOS. Three standard display formats are available.

- A) Displacement in figures
- B) Displacement in figures and a bar chart
- C) Graphically, displacement and time X-Y axis.  
User specified ranges.

Date, time, displacement and sensor temperature can be logged at user specified time intervals. This log enables fall rates to be easily determined and pistons to be partially characterised. The sensors are fully temperature compensated. The sensor temperature is simultaneously displayed with displacement. A special calibration stand is provided with a 0.001 mm static head micrometer to calibrate, linearise and check the sensor output.

This option is not easily retrospectively fitted.

#### **10.4 MOTOR DRIVE**

In standard form the masses are rotated manually. Some applications need motor drive, e.g. long term stability tests, and this is available as an option. The motor drive has been designed to introduce minimum disturbance to:-

- noise level
- thermal stability
- vertical force of the floating mass
- piston sensitivity

This can be supplied either AC 220/240V or AC 110/120V, please specify when ordering.

This option is not easily retrospectively fitted.

#### **10.5 HAND PUMP**

If large volumes need to be pressured then a Hydraulic Hand Pump is available. This is a stand-alone unit which is placed to the right of the pressure standard. A stainless steel pipe connects to the port that is already available on the pressure standards manifold. The Hand Pump is fitted with a half litre reservoir and a valve for venting to atmosphere. The Hydraulic Hand Pump is for pre-priming and initial pressurisation to 20 bar, 300 psi. 90% of the compression in the Hydraulic system will be taken up in this initial pressurisation. There is then sufficient volume in the ram screw to generate higher pressures. Using the ram screw for the main proportion of the calibrated pressure range, ensures good control for both rising and falling pressures.

## 10.6 PRESSURE CONTROLLER

Currently for all hydraulic models a pressure controller can be supplied, consisting of a piston position sensor, a motorised screw press and controller. The controller can be operated manually or through a computer.

There are two particular applications where the pressure controller can enhance the calibration process:

1. Where the calibration requires optimum conditions for hysteresis measurement.
2. For instrument stability tests over an extended period of time.

### HYSTERESIS

To best measure hysteresis, it is essential that the calibration point is achieved with the minimum overshoot and in the most reproducible manner. This is very difficult to achieve with manual operators, as each one will have slightly different techniques. Even a single operator will introduce minor variations each time so that the level of repeatability at any pressure point will vary in a random way.

It is not possible to achieve a rising pressure point without some overshoot. As the masses are stationary prior to floatation they will require an acceleration to lift them off the bottom travel limit and this force must come from excess pressure applied to the system. With a manual operator the amount of additional force will vary with each pressure point.

The addition of a piston position sensor and a motorised screw press with controller will minimise the overshoot problem. Whilst it will not eliminate overshoot, it will give the best repeatable results for each pressure point.

### EXTENDED STABILITY TEST

There are many applications where it is essential to know how a particular instrument (e.g: pressure transducer, or pressure transmitter) performs under steady state conditions, so that any drift or creep can be observed and their limitation on the performance of the instrument established.

The pressure standard has a continuous (albeit small) leak between the piston and cylinder. The piston has a finite travel, and to keep the piston floating the screw press has to be adjusted from time to time. If this process is required for only a short time, then there is no problem. However, frequently extended pressure tests cover a period of days, weeks or even months. Under these circumstances it is obviously impractical to use the manual system and the combination of a motor drive, piston position sensor and motorised screw press and controller is the ideal solution.

This option is not easily retrospectively fitted.

## 11.0 FAULT FINDING

### 11.1 POOR PISTON SPIN/SENSITIVITY

IF PISTON IS NOT FREE, DO NOT ROTATE AS DAMAGE MAY OCCUR,  
DISMANTLE AND CLEAN - SEE SECTION 8.0.

- 11.1.1 Screw Capstan fully out and open Reservoir Valve (7)
- 11.1.2 For PCU 22, 23, 24, 25 & 32, remove the Weight Carrier Assembly.
- 11.1.3 Holding the Piston Cap, lift gently up and down. The Piston should slide freely within its Cylinder, if any resistance or a 'gritty' sensation is detected, then it must be cleaned, see Section 8.0.
- 11.1.4 If spin/sensitivity of a cleaned Piston deteriorates quickly then it is likely that the operating oil within the system is contaminated. This must be drained out, the system cleaned and re-primed with clean oil.

### 11.2 SYSTEM WILL NOT PRIME OR PRESSURISE

- 11.2.1 Check Valve (7 ) is closed.
- 11.2.2 Check there is sufficient fluid in the Reservoir (8).
- 11.2.3 Check for damaged/missing/dirty seals. Tighten, clean or replace seal as required.
- 11.2.4 Check that instrument under test is not leaking.
- 11.2.5 Check system for leaks by looking for drips at joints whilst continually pressurising. Replace Seal/Part, ensuring that sealing faces are clean and undamaged when re-assembling.

### 11.3 PISTON DROPS QUICKLY

GENERAL: The Piston will always drop slowly due to a small leak between the Piston and Cylinder. This drop rate will never be so quick that a stable reading cannot be made.

- 11.3.1 If the system has been pressurised quickly then it must be allowed to thermally stabilise. Continue re-floating the Piston until it stabilises, this should take no longer than one minute.
- 11.3.2 Check 11.2.

- 11.3.3 IF PCU HAS JUST BEEN RE-FITTED AFTER CLEANING:  
Air pockets can be introduced when re-fitting PCU. This will cause the Piston to drop faster whilst the air bleeds past the Piston and Cylinder.  
Continue to re-float the Piston until the drop-rate slows down. If the Piston continues to drop quickly then check the fluid leakage around the base of the PCU.
- 11.3.4 Valve (7) leaking.  
Remove Reservoir Cover and observe fluid level, it will rise slowly if the valve leaks. This indicates that the valve seat may be damaged or dirty. It should be disassembled, cleaned and inspected, then re-tested or replaced as necessary.
- 11.3.5 Rambler Seal (42) leaking. Check Ram Screw (48) for 'wetness' when extended. (Should be greased, not running with operating fluid). If Ram Screw is 'wet', then replace the Rambler Seal (42) with the spare provided.

#### 11.4 CANNOT ATTAIN MAXIMUM PRESSURE HAVING SCREWED CAPSTAN FULLY IN

- 11.4.1 Check 11.2.
- 11.4.2 If the instrument under test has a large internal volume or there is air in the system, then re-prime, see Section 7.2 to 7.5.

#### 11.5 HAND-PUMP MALFUNCTION (OPTIONAL EQUIPMENT)

- 11.5.1 Check 11.2
- 11.5.2a If pumping generates no pressure, then the Inlet Non-Return Valve has probably failed.
- 11.5.2b This should be disassembled and inspected for dirt or damage to valve seat and Seal. After inspection, clean all parts thoroughly, replace as required and re-assemble correctly.
- 11.5.3 If the system pressurises and depressurises in conjunction with the downward and upward strokes of the Pump, then the Outlet Non-Return Valve has failed completely. Inspect as per 11.5.2b.
- 11.5.4 If the Pump Handle rises, then the Outlet Non-Return Valve is leaking. Inspect as per 11.5.2b.

**Note: Do not continue to pressurise if Pump Handle rises, as this can damage the pump Inlet Non-Return Valve.**



## 12.0 RECALIBRATION

The accuracy depends primarily on the effective area of the PCU's and the mass of the masses.

For high accuracy systems such as the P7000 series, the PCU's and weight masses should be calibrated every two years. After some history on the PCU a more precise recalibration period can be defined. The recalibration period should also take into account the number of times the PCU is used.

Overhaul and/or recertification should be carried out if either:

- (a) The piston performance degrades (spin, sensitivity, fall rate)
- (b) The masses are damaged or corroded
- (c) The pressure system becomes contaminated

The recalibration frequency must ultimately be determined, with reference to the above comments and any organisational or inspection authority requirements.

**Accuracy:** 50 ppm of reading + 0.035 ppm per bar (+ 0.0025 ppm per psi)

PCU:	Sensitivity	1 ppm *	
	Repeatability	3 ppm *	
	Reproducibility	6 ppm / year *	* Full Scale

**Pressure Ranges:**

Gas	15 mbar to	140 bar /	0.25 to	2000 psi
Oil	4	to 1400 bar /	50	to 20000 psi
Water	4	to 350 bar /	50	to 5000 psi

**Material of Masses:** Series 3 non-magnetic, austenitic stainless steel.

**Density of Masses:** 7.9 g/cm<sup>3</sup>

**Reference Temperature:** 20°C

**Temperature Range:** (Operating) 12 to 28°C  
(Storage) - 40 to 70°C

**Test Station Adaptors:** 1/8"; 1/4"; 3/8"; 1/2" BSP or NPT (As specified)

**External Port (Hydraulic):** 1/8" BSP

**Inlet Port (Gas):** 1/8" BSP

**Instrument Size Single Base:** 52 x 38 x 37 cm L x D x H

**Instrument Size Dual Base:** 79 x 38 x 37 cm L x D x H

**Instrument Weight, Dual Base:** 27 kg

<b>Total Mass Set Weight:</b>	WT1	8 kg
	WT2	58 kg
	WT3	116 kg
	WT5	4 kg
	WT6	29 kg
	WT7	58 kg

## AIR DENSITY IN g/ml

Humidity: 50%  
 Atmospheric Pressure: 750 to 780 mmHg (At 0 °C)  
 Temperature: 18 to 28 °C

Air Temp. °C	Atmospheric Pressure (mmHg at 0 °C)						
	750	755	760	765	770	775	780
18	.001192	.001200	.001208	.001216	.001224	.001232	.001240
19	.001187	.001195	.001203	.001211	.001219	.001227	.001235
20	.001183	.001191	.001199	.001207	.001215	.001223	.001231
21	.001179	.001187	.001195	.001202	.001210	.001218	.001226
22	.001174	.001182	.001190	.001198	.001206	.001214	.001222
23	.001170	.001178	.001186	.001194	.001202	.001209	.001217
24	.001166	.001174	.001182	.001189	.001197	.001205	.001213
25	.001162	.001169	.001177	.001185	.001193	.001201	.001208
26	.001157	.001165	.001173	.001181	.001188	.001196	.001204
27	.001153	.001161	.001168	.001176	.001184	.001192	.001199
28	.001149	.001156	.001164	.001172	.001180	.001187	.001195

For fractional and non-listed values of pressure and temperature, the following equation may be used to calculate air density values with an accuracy of 0.000001 g/ml:

$$R = 0.0011988 + 0.0000044 \times (20 - T) + 0.0000016 \times (P - 760)$$

Where: R = Air Density  
 P = Atmospheric Pressure in mmHg  
 T = Temperature in °C

For atmospheric pressure measured to 1 mmHg (1.33 mbar) and temperatures to 0.25 C, the total uncertainty with the use of this equation is 0.0000015 g/ml.

For variations in humidity between 25% and 75%, the air density values in the 50% humidity table above will vary up to +/- 0.00004 g/ml.

This variation has an insignificant effect on the measured pressure, less than 0.7 ppm.

**PISTON AND CYLINDER UNIT (REFERENCES AND RANGES)**

---

Operating Media	Reference	Pressure Range			
Air	* PCU11	15	to	1000 mbar,	0.25 to 15 psi
	* PCU12	30	to	2000 mbar,	0.5 to 30 psi
	* PCU13	0.25	to	10 bar,	5 to 150 psi
	* PCU14	0.25	to	35 bar,	5 to 500 psi
	PCU15	15	to	70 bar,	100 to 1000 psi
	PCU16	15	to	140 bar,	100 to 2000 psi
Oil	PCU21	4	to	35 bar,	50 to 500 psi
	PCU22	15	to	140 bar.	200 to 2000 psi
	PCU23	35	to	350 bar.	500 to 5000 psi
	PCU24	35	to	700 bar,	500 to 10000 psi
	PCU25	70	to	1400 bar,	1000 to 20000 psi
	PCU26	4	to	70 bar,	50 to 1000 psi
Distilled or Deionised Water	PCU31	4	to	35 bar,	50 to 500 psi
	PCU32	35	to	350 bar,	500 to 5000 psi

---

\* Fitted with a 'table top' mass carrier, all other PCU's use an 'overhanging' mass carrier.

---

OPERATING MEDIA	PRESSURE RANGE	SYSTEM MODEL	PISTON CYLINDER UNITS	MASS SET
GAS	15 mbar to 10 bar 0.25 to 150 psi	P7510	PCU 11, 12, 13	WT5
GAS	0.25 to 140 bar 5 to 2000 psi	P7520	PCU 13, 14, 15, 16	WT6
GAS	15 mbar to 140 bar 0.25 to 2000 psi	P7530	PCU 11, 12, 13, 14, 15, 16	WT6
OIL	4 to 350 bar 50 to 5000 psi	P7600	PCU 21, 22, 23	WT6
OIL	4 to 1400 bar 50 to 20000 psi	P7700	PCU 21, 22, 23, 24, 25, 26	WT7
WATER	4 to 350 bar 50 to 5000 psi	P7600W	PCU 31, 32	WT6

**DUAL BASE DEADWEIGHT TESTER CALIBRATION MODELS**

OPERATING MEDIA	PRESSURE RANGE	SYSTEM MODEL	PISTON CYLINDER UNITS	MASS SET
GAS	15 mbar to 10 bar 0.25 to 150 psi	P7110	PCU 11, 12, 13	WT1
GAS	0.25 to 140 bar 5 to 2000 psi	P7120	PCU 13, 14, 15, 16	WT2
GAS	15 mbar to 140 bar 0.25 to 2000 psi	P7130	PCU 11, 12, 13, 14, 15, 16	WT2
OIL	4 to 350 bar 50 to 5000 psi	P7200	PCU 21, 22, 23	WT2
OIL	4 to 1400 bar 50 to 20000 psi	P7300	PCU 21, 22, 23, 24, 25, 26	WT3
WATER	4 to 350 bar 50 to 5000 psi	P7200W	PCU 31, 32	WT2