

THE PDW SERIES OF PORTABLE HYDRAULIC DEADWEIGHT TESTERS

USER MANUAL



SI-BARNET DEADWEIGHT TESTER

PDW SERIES

Release: S421-209-80

Revision: A

Date: 04/30/03

MANUFACTURED BY:

GE RUSKA

RUSKA INSTRUMENT CORPORATION
10311 WESTPARK DRIVE, HOUSTON, TEXAS 77042
P = (713) 975-0547 F = (713) 975-6338
e-mail: ruska@ruska.com



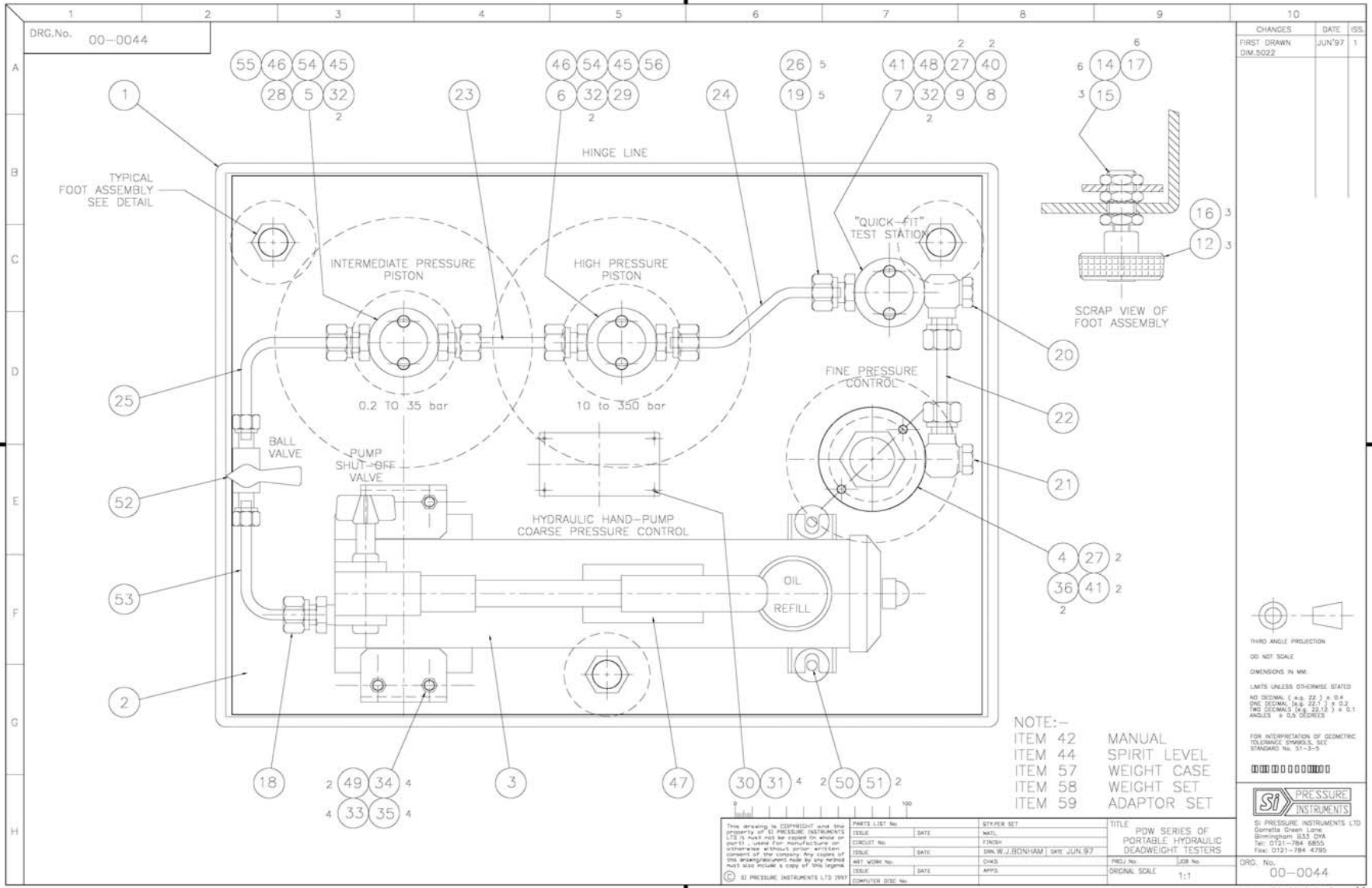

TABLE OF CONTENTS

	PAGE
SPECIFICATION	-1-
DESCRIPTION	-2-
OPERATION.....	-3-
OPERATION OF DOUBLE PISTON DEADWEIGHT TESTER	-4-
MAINTENANCE.....	-6-
USER SPARES LIST.....	-6-
PRESSURE CORRECTIONS	-7-
TEMPERATURE AND GRAVITY CORRECTIONS	-8-
HEIGHT CORRECTIONS	-8-

Please read these instructions carefully prior to installing and using the Tester. The pressure built up internally during use can be extremely high. Ensure that all connections are made correctly.

SPECIFICATION

MODELS: Single Piston or Double Piston

RANGE: 0.2 bar to 350 bar or equivalents in other units as required (see Table 1).

ACCURACY: (see Calibration Certificate)

TRACEABILITY: To NIST, NVLAP accredited calibration optional

STANDARD CORRECTIONS:
Gravity: 9.80665 m/s²
Temperature: 20°C
Air Density: 1.2 kg/cu.m

WEIGHTS: Non-magnetic Stainless Steel contained in an Aluminum case.

OPERATING MEDIUM:
Hydraulic oil - DW6293

WEIGHT: DWT: 15 kg
Weights: 18 kg approx.

DIMENSIONS: DWT: 465 mm x 225 mm x 210 mm high.
Weights: 240 mm x 225 mm x 250 mm high.

STANDARD ACCESSORIES:
See Table 2

OPTIONAL ACCESSORIES:
See Table 2

ORDERING CODES:
See Table 1.

DESCRIPTION

The PDW Series is a range of portable hydraulic Deadweight Testers designed for ruggedness and convenience of use in harsh "onsite" environments.

The Deadweight Tester comprises a base plate onto which is mounted either one or two PCU (piston/cylinder) assemblies depending on pressure range (see Table 1), a hydraulic hand-pump with a capacity of 200 cc's for generating coarse pressure, a fine control valve for precise pressure control and a "quick-fit" type test station for easy mounting of the instrument under test. The whole assembly is contained in a sturdy aluminum carrying case complete with shoulder strap and three adjustable feet for easy leveling. A set of stainless steel weights is provided which is also housed in its own aluminum carrying case.

A list of standard and optional accessories is shown in Table 2. The whole system is easily carried by one person, the total weight being approximately 30 kg.

TABLE 1

ORDER CODE	NO. OF PISTONS	lbf/in²	kgf/cm²	bar	WEIGHTS PER SET
PDW120/4	1	4 to 500			12
PDW120/5	1		0.2 to 35		13
PDW120/6	1			02. to 35	13
PDW150/4	1	100 to 5000			12
PDW150/5	1		10 to 350		13
PDW150/6	1			10 to 350	13
<hr/>					
PDW230/4	2	4 to 5000			12
PDW230/5	2		0.2 to 350		13
PDW230/6	2			0.2 to 350	13

OPERATION

The PDW Series of Deadweight Testers are very easy instruments to use. They are basically divided into two types:

- a. Single Piston.....LOW or HIGH PRESSURE
- b. Double Piston...LOW & HIGH PRESSURE

Before using the Deadweight Tester ensure that:-

1. The Deadweight Tester is level. This is achieved by placing the spirit level on the weight carrier and adjusting the leveling feet.
2. No pressure exists in the system. This is achieved by opening ball valve (handle in line with pipe) and by turning the release valve on the hydraulic hand-pump fully anticlockwise.
3. Either the item under test or a blanking plug is connected to the "quick-fit" test station. Under no circumstances must the Deadweight Tester be pressurized with the quick-fit couplings in the uncoupled condition.

OPERATION OF SINGLE PISTON DEADWEIGHT TESTER

To generate pressure, load the piston/carrier assembly with a weight so that the sum of the pressure marked on the weight and on the carrier is equal to the pressure required. Close the release valve on the hand-pump by turning fully clockwise. Using short strokes, operate the pump until the weights start to rise. Close the ball valve (handle at right angle to pipe) and rotate the weights in a clockwise direction at a speed of approximately 60 rpm. Using the fine control valve adjust the height of the weights so that the bottom edge of the weight carrier is approximately level with the top edge of the carrying case (see Figure 1).

To increase pressure, stop rotation of existing weights and add more weights as required. Open ball valve and repeat procedure as before.

To reduce pressure, stop rotation of existing weights and remove weights as required. Adjust fine control valve until the remaining weights are 'floating' again. If there is not enough adjustment on the fine control to achieve this, open ball valve and carefully reduce pressure via the release valve on the hand-pump by slowly turning anticlockwise until the weights start to fall and then close again by turning fully clockwise. Close ball valve and again rotate the weights and adjust to the correct level using the fine control valve.

To release all pressure from the system open ball valve and turn release valve on the hand-pump fully anticlockwise.

OPERATION OF DOUBLE PISTON DEADWEIGHT TESTER

The operating procedure is the same as for the single piston machine except that it should be noted that the weights are double marked, e.g. 100/1000 psi. This means that when calculating pressures, the lower value should be used when the weights are on the LOW pressure piston and the higher value used when the weights are in the HIGH pressure piston.

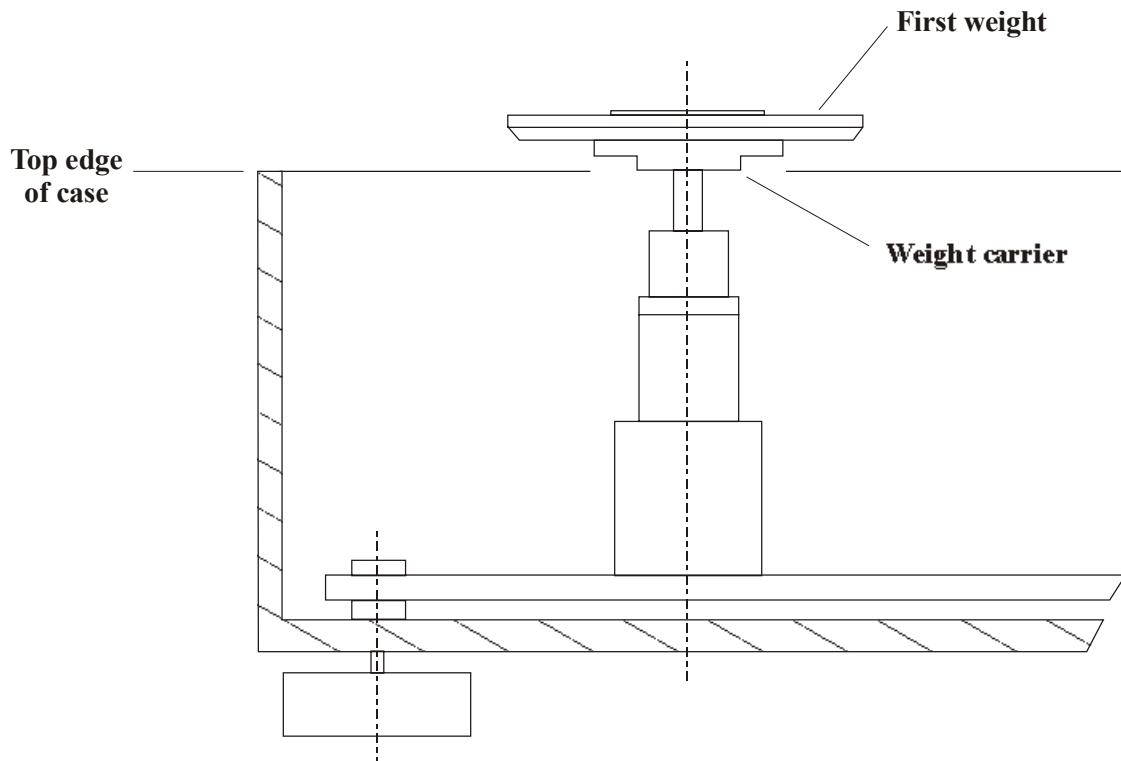

FIGURE 1
'MID-FLOAT' POSITION OF PDW DEADWEIGHT TESTER WEIGHTS

*

**TABLE 2
ACCESSORIES**

ITEM	DESCRIPTION
STANDARD ACCESSORIES	
1	Certificate of Accuracy of Deadweight Tester
2	Certificates of Test and Inspection for Deadweight Tester PCU Assemblies
3	User Manual (this manual)
4	Plastic case containing set of adaptors & seals.
5	Spirit level
6	Aluminum case containing set of Stainless Steel weights
OPTIONAL ACCESSORIES	
7	Conversion Weights Set: converts any specified Deadweight Tester for use with any alternative unit of pressure.
8	Fractional Weight Set: allows smaller increments of pressure to be generated and measured.
9	Fluid Separator: connects directly to a PDW Series Deadweight Tester and provides a flexible baffle between the fluid in the Deadweight Tester and the fluid in the item under test.
10	Flexible hose 1.5 meters long fitted with "quick-fit" couplings and rated at 400 bar working pressure.

MAINTENANCE

The PDW Series of Deadweight Testers have been designed to require minimal maintenance. Routine maintenance entails keeping the equipment free from dirt and dust and ensuring that the lid is closed when the Deadweight Tester is not in use.

Repair maintenance is limited to the self evident replacement of seals, felt pads and hydraulic fluid.

WARNING: If hydraulic fluid contacts the skin, an allergic reaction may result. Wash using soap and water.

USER SPARES LIST:

DESCRIPTION	PART NUMBER	NO. OFF
1/8" BSP Bonded Seal	DWSKPDW	8
1/4" BSP Bonded Seal		4
3/8" BSP Bonded Seal		2
L.P. Piston Seal		2
H.P. Piston Seal		2
Felt Pads		2
Male Quick-Fit Coupling		2
Hydraulic Fluid (1 liter)		1

PRESSURE CORRECTIONS

Pressure correction is required for high accuracy work and is due to the effects of pressure on the PCU assembly during operation. By reference to the certificate of calibration provided the actual pressure in the system can be obtained. All values relate to the environmental conditions stated on the certificate.

The pressure in the system when the carrier is loaded with major weights can be read directly from the second column of the certificate.

The pressure in the system when the carrier is loaded with incremental weights is given together with the pressure in the system when the carrier is loaded with major and incremental weights. From these values, assuming effects are linear, the incremental weight corrections over the range may be calculated.

If the DWT is located at a position where the values of the gravitational acceleration and temperature of operation are the same as those values specified for calibration, then the Actual Pressure is fully corrected. If the DWT is used under different conditions then further correction is necessary (see Figure 4).

The Pressure Reference Level is specified on the certificate.

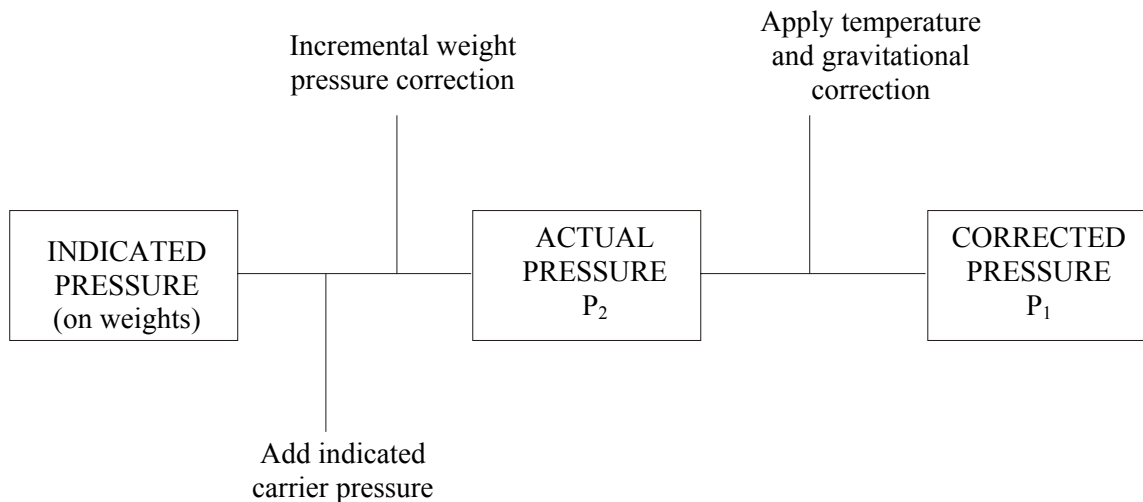

FIGURE 4
PRESSURE CORRECTIONS

TEMPERATURE AND GRAVITY CORRECTIONS

Deadweight Testers are manufactured to give accurate pressure reference at the specified temperature and gravity values indicated on the certificates. The following Standard Values are applied during calibration unless otherwise requested during manufacture (see certificate).

Standard Gravitational acceleration (G)	9.80665 m/s ²
Standard Temperature (T)	20°C

$$P_1 = P_2 \left(1 + \alpha(T - t) \right) \frac{g}{G}$$

Where:

P_1	=	Corrected Pressure
P_2	=	ACTUAL PRESSURE
α	=	Coefficient of Linear Expansion (The value for a specific piston / cylinder assembly (PCU) is shown on the Calibration Certificate)
T	=	DWT calibrated temperature (°C)
t	=	Temperature at position of DWT (°C)
g	=	Gravitational acceleration at position of DWT
G	=	DWT calibrated gravitational acceleration

The value of gravitational acceleration (g) varies with latitude, height above sea level and geological conditions at the location of the DWT. When the gravitational acceleration varies from that for which the DWT was calibrated, the above correction must be made. The local value of gravitational acceleration (g) can be obtained as follows:

Data from the appropriate geophysical authority.

Approximated from the Nomogram (Figure 5).

Calculated from the formula:

$$g = 9.7803184 \left(1 + 0.0053024 \sin^2 L - 0.0000059 \sin^2 2L \right) - 0.000003086 H$$

where:

L = geographical latitude, H = height above sea level in meters and units of g are m/sec²

HEIGHT CORRECTIONS

Tests carried out at locations other than the test stations may require corrections for fluid heights. The pressure exerted by a column of fluid 25.4 mm high will not exceed 0.0025 bar using the recommended fluids.

Explanation of Nomogram
 A straight line passing through the known values of altitude (H) and latitude (L) of the site of the DWT, when extended to scale g, will indicate the approximate value of g.

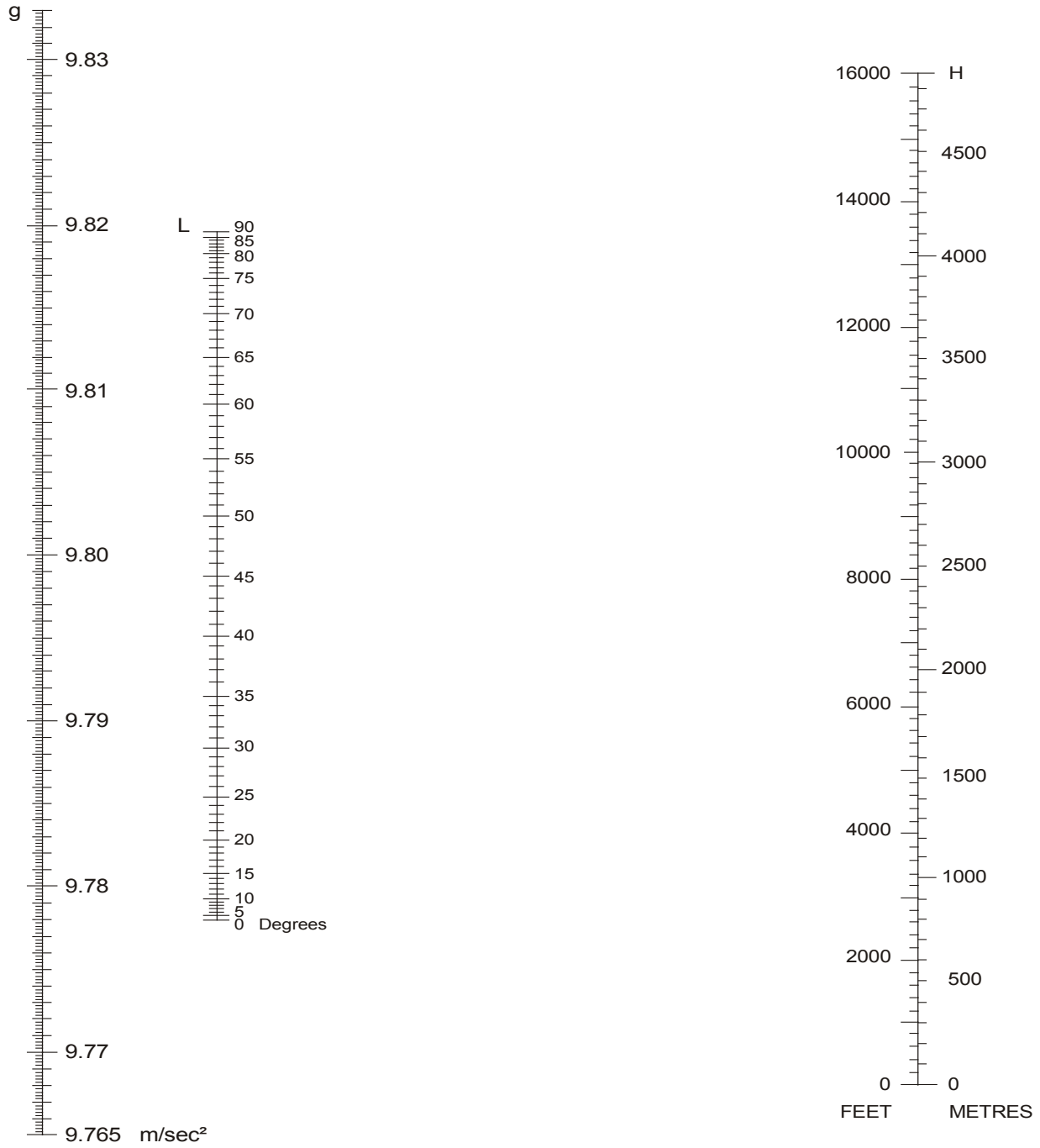

FIGURE 5
NOMOGRAM FOR FINDING THE VALUE OF 'g' FROM ALTITUDE AND LATITUDE