

Temperature

Piston pressure gauges are temperature sensitive and must, therefore, be corrected to a common temperature datum.

Variations in the indicated pressure resulting from changes in temperature arise from the change in effective area of the piston due to expansion or contractions caused by temperature changes. The solution is a straightforward application of the thermal coefficients of the materials of the piston and cylinder. The area corresponding to the new temperature may be found by substituting the difference in working temperature from the reference temperature and the thermal coefficient of area expansion in the relation as follows:

$$A_{0(t)} = A_{0(r)} [1 + c(t-r)]$$

Where:

$A_{0(t)}$	is the effective area at temperature, t
$A_{0(r)}$	is the effective area at zero pressure and reference temperature, r
c	is the coefficient of thermal expansion

Reference Plane of Measurements

The measurement of pressure is linked to gravitational effects on the pressure medium. Whether in a system containing a gas or a liquid, gravitational forces produce vertical pressure gradients that are significant and must be evaluated. Fluid pressure gradients and buoyant forces on the piston of a pressure balance require the assignment of a definite position at which the relation $P = F/A$ exists.

It is common practice to associate this position directly with the piston as the datum to which all measurements made with the piston are referenced. It is called the reference plane of measurement, and its location is determined from the dimensions of the piston. If the submerged portion of the piston is of uniform cross section, the reference plane is found to lie conveniently at the lower extremity as shown in Figure 2-4. If, however, the portion of the piston submerged is not uniform, the reference plane is chosen at a point where the piston, with its volume unchanged, would terminate if its diameter were uniform.

The reference plane of the standard is the effective bottom of the measurement piston. This location can be correlated to the index on the mass stack using the L1 dimension (found on Calibration Report for the Piston/Cylinder) and the D Dimension (found on Calibration Report for the Mass set).

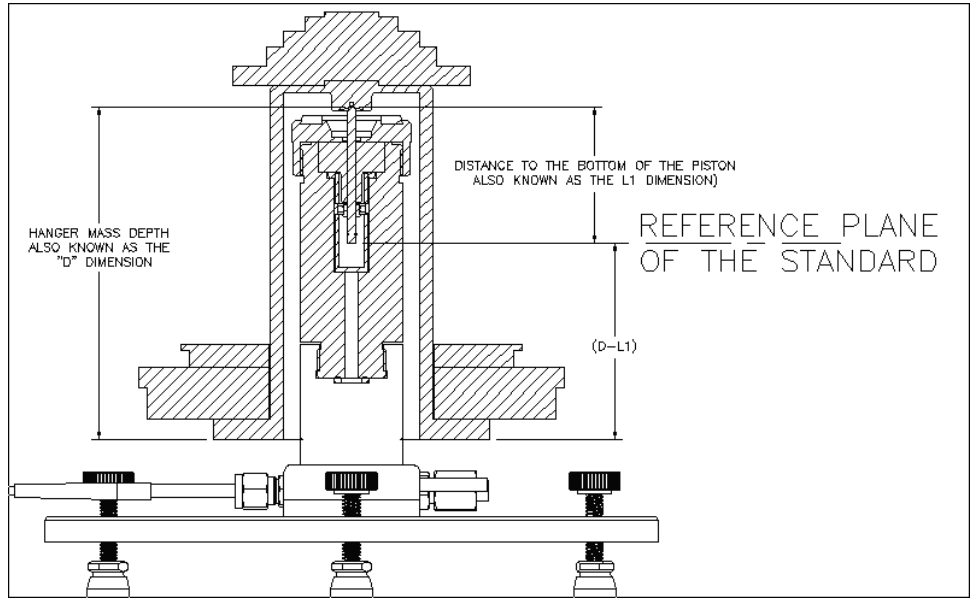

glg02.bmp

Figure 2-4. Reference Plane Determination

When a pressure for the piston pressure gauge is calculated, the value obtained is valid at the reference plane. The pressure at any other plane in the system may be obtained by multiplying the distance of the other plane from the reference plane by the pressure gradient and adding (or subtracting) this value to that observed at the piston reference plane.

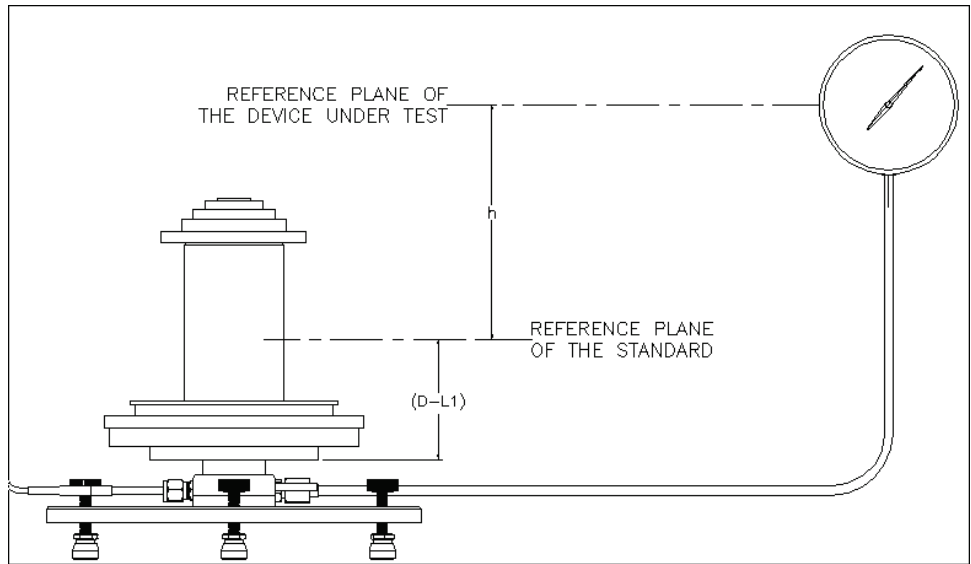

glg03.bmp

Figure 2-5. Head Correction Measurement