

SafeCount™



Installation Guide

INSTALLATION GUIDE

- 1** EQUIPMENT REQUIRED
- 2** YOUR SAFECOUNT SENSOR
- 3** SYSTEM OVERVIEW
- 4** PRIMARY SENSOR INSTALLATION
- 5** SECONDARY SENSOR INSTALLATION
- 6** SYSTEM CONFIGURATION
- 7** UNDERSTANDING DEVICE LEDs
- 8** DISCLAIMER

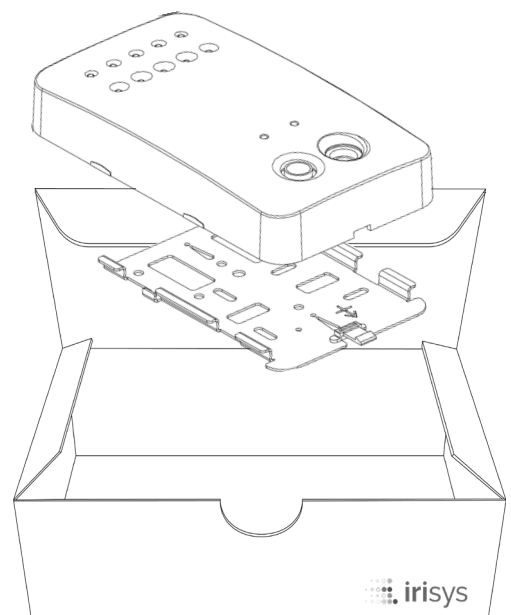

1 EQUIPMENT REQUIRED

The following equipment is required for a complete system, most of which will already be present in a typical setup.

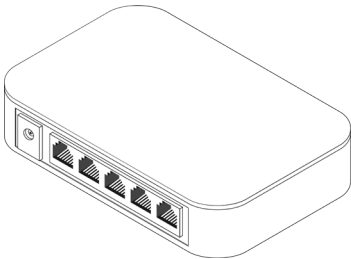

PoE SWITCH

The SafeCount Primary Sensor and/or SafeCount Secondary Sensor requires a Power over Ethernet (PoE) Switch in order for the SafeCount Sensor to be powered

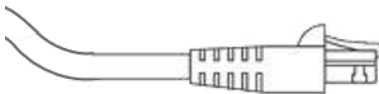

CAT5/6 ETHERNET CABLES

Your SafeCount Primary Sensor should be connected to a PoE Switch on your network via CAT 6 Ethernet

- Cables with a maximum length of 100m / 328 ft.
- CAT5 Cables can be used, however we recommend CAT6 or better, with gauge AWG 22 or 23.

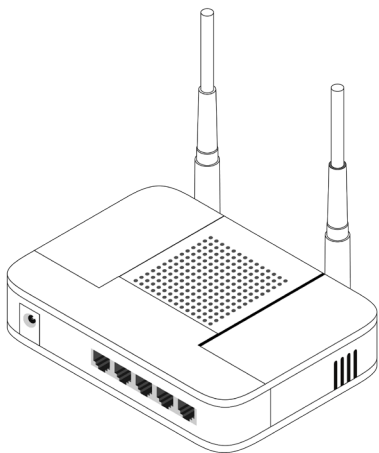

WIFI ROUTER (RECOMMENDED)

A WiFi Router is recommended and should have a wired connection to your PoE Switch.

IMPORTANT - Without a WiFi Router, the SafeCount Sensors will not be assigned (DHCP) IP addresses and will revert to a default IP Address of 192.168.0.10. Each Sensor will need to be configured (in turn) with a unique manual IP address. We recommend contacting your Network Administrator for guidance on how to configure manually.

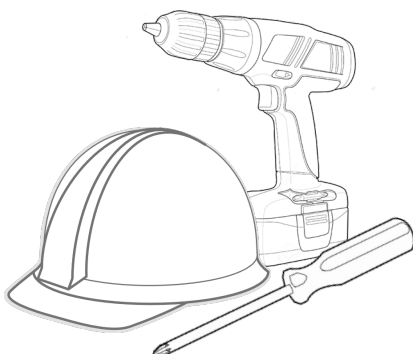

SUITABLE TOOLS & PPE

You will also require suitable tools to mount each SafeCount Sensor and personal protective equipment (PPE), especially when working at height.

2 YOUR SAFECOUNT SENSOR

Your SafeCount Sensor is the most important part of your new counting solution, so it is important to familiarize yourself with the Sensor and its key component parts.

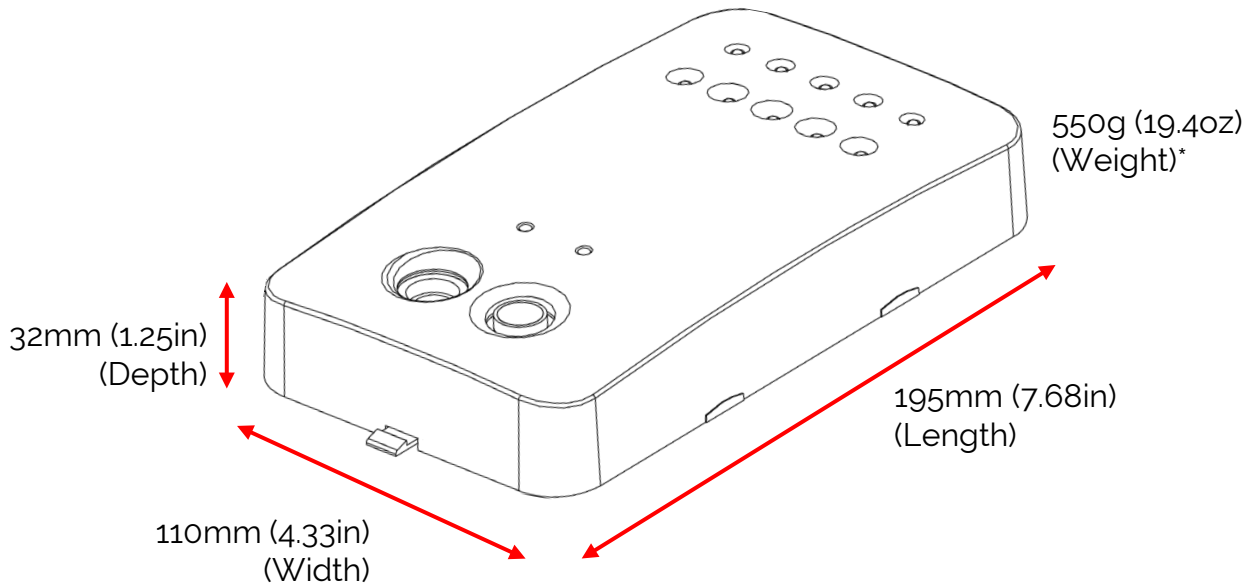

*The SafeCount Sensor weighs approx. 550g (19.4oz), so always use appropriate fixings to secure the base plate in place.

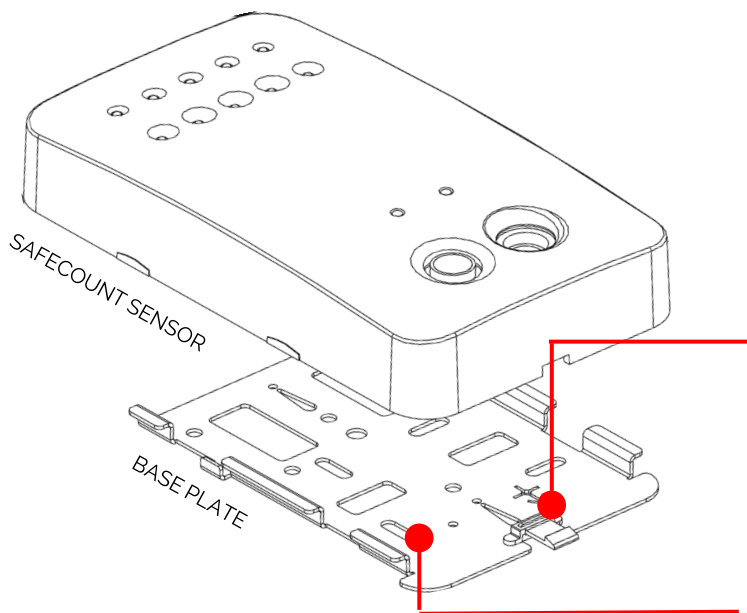

There is a white plastic clip at the top of the base plate, which allows the SafeCount Sensor to be separated from it when required

The base plate has a number of screw holes for complete flexibility when fixing to the ceiling

2 YOUR SAFECOUNT SENSOR

Please familiarize yourself with the underside of your SafeCount Sensor and the key component parts that can be found there.

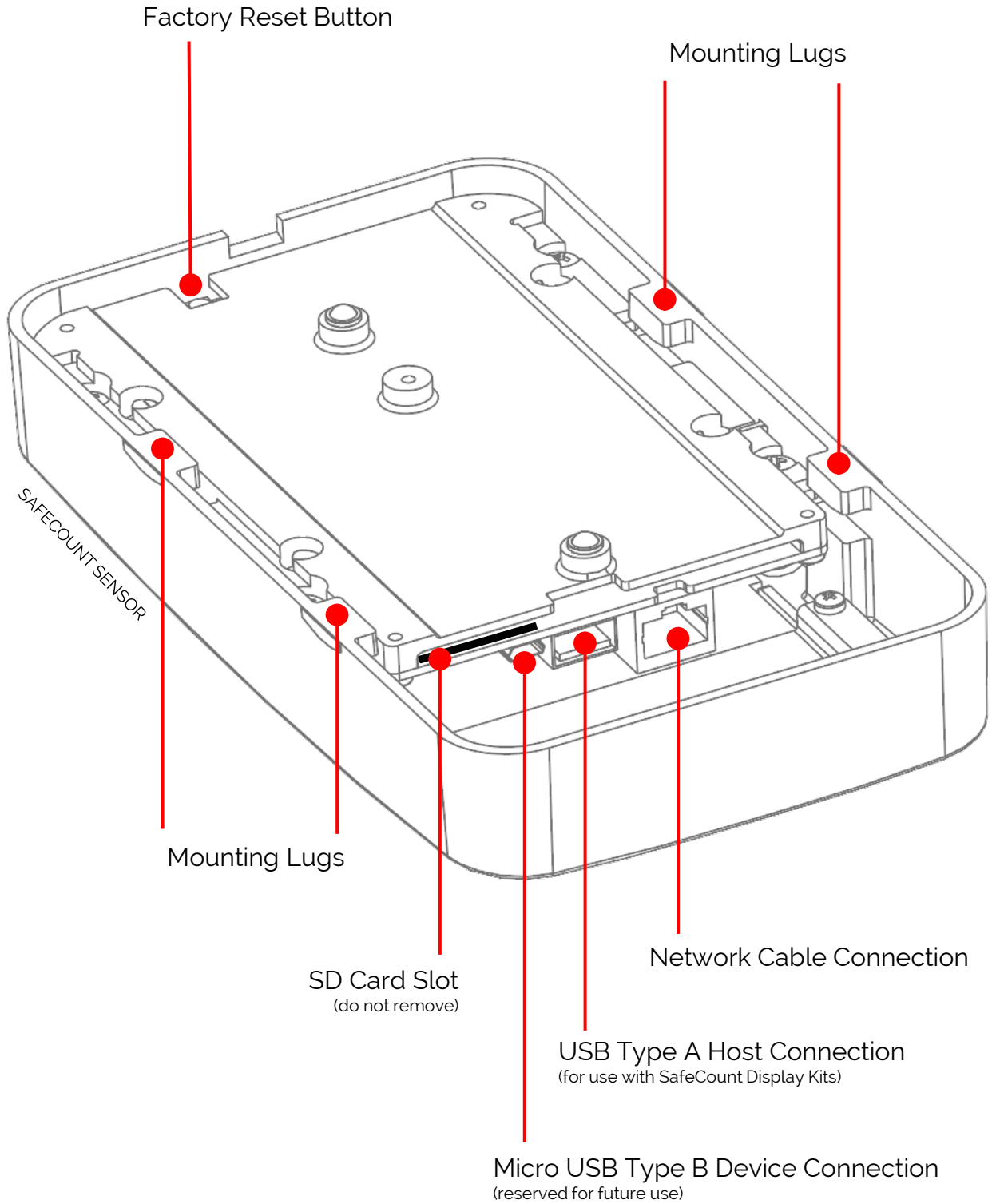

3 SYSTEM OVERVIEW

Before starting your installation, it is important to understand how your new SafeCount Sensor - as well as any SafeCount Secondary Sensors you may have - are connected with your own equipment, to form a complete system.

SafeCount Primary Sensor

Installed at Primary Entrance

SafeCount Secondary Sensors

Installed at Secondary Entrances (Up to maximum of 20)

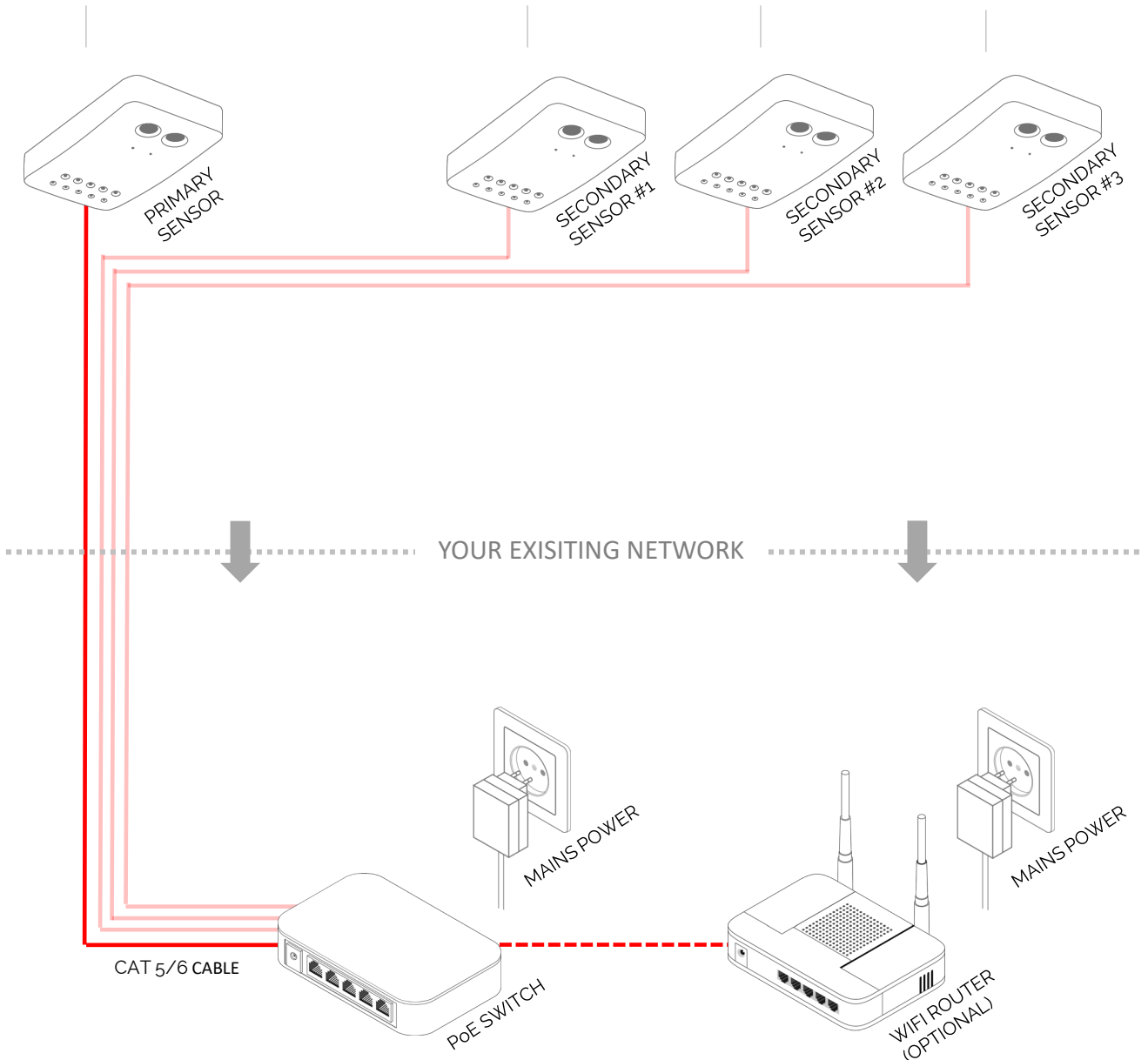

If your SafeCount system **does not include** a WiFi Router, please follow the instructions on the following page to manually set each SafeCount sensors IP address.

3 SYSTEM OVERVIEW

If your setup **does not include** a WiFi Router, then your SafeCount Sensors will not be assigned (DHCP) IP addresses and will each revert to a default IP Address of 192.168.0.10.

Each Sensor will need to be configured (in turn) with a unique **manual IP address**. We recommend contacting your Network Administrator for guidance on how to configure manually.

You should plug each Sensor in one-by-one when configuring their IP addresses, as having multiple devices with the same IP address on the network can lead to unforeseen issues. We would further recommend setting these unique addresses prior to installing on the ceiling, but it is equally possible to do so after the Sensors have been ceiling mounted, provided only one Sensor is powered and configured at a time.

Your SafeCount Sensors should be configured in line with your own network architecture needs and if required, you should **consult your IT department or network administrator** for how best to configure the devices to match your corporate network needs.

SafeCount Primary Sensor

Installed at Primary Entrance

SafeCount Secondary Sensors

Installed at Secondary Entrances (Up to maximum of 20)

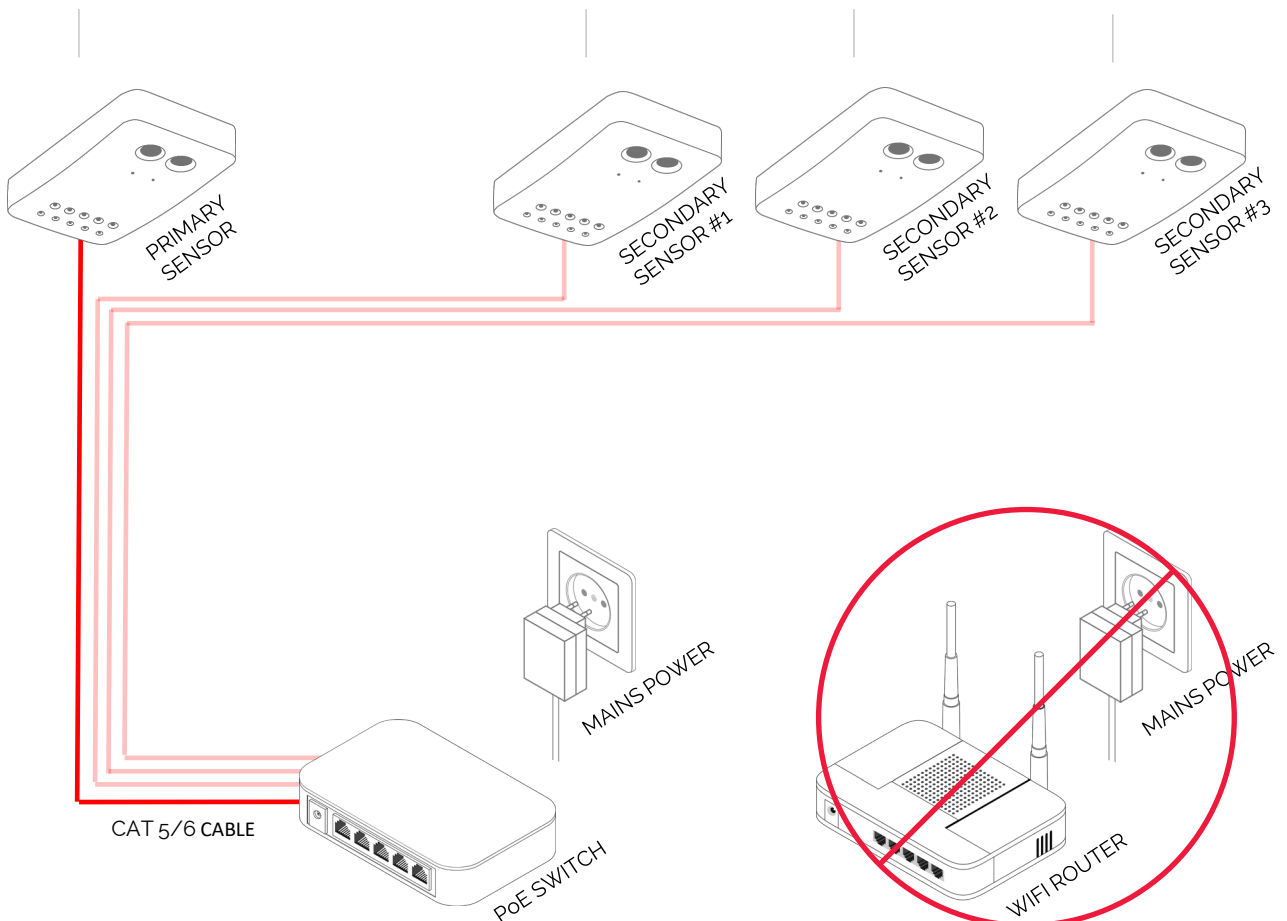

4 PRIMARY SENSOR INSTALLATION

Your SafeCount Primary Sensor should be installed at the main entrance (and exit) of your designated building.

We recommend that you **measure and record** the maximum width of your chosen doorway as well as the ceiling height in front of the doorway, so that you can more accurately position your SafeCount Primary Sensor. Your measurements will be needed to determine the optimum mounting location.

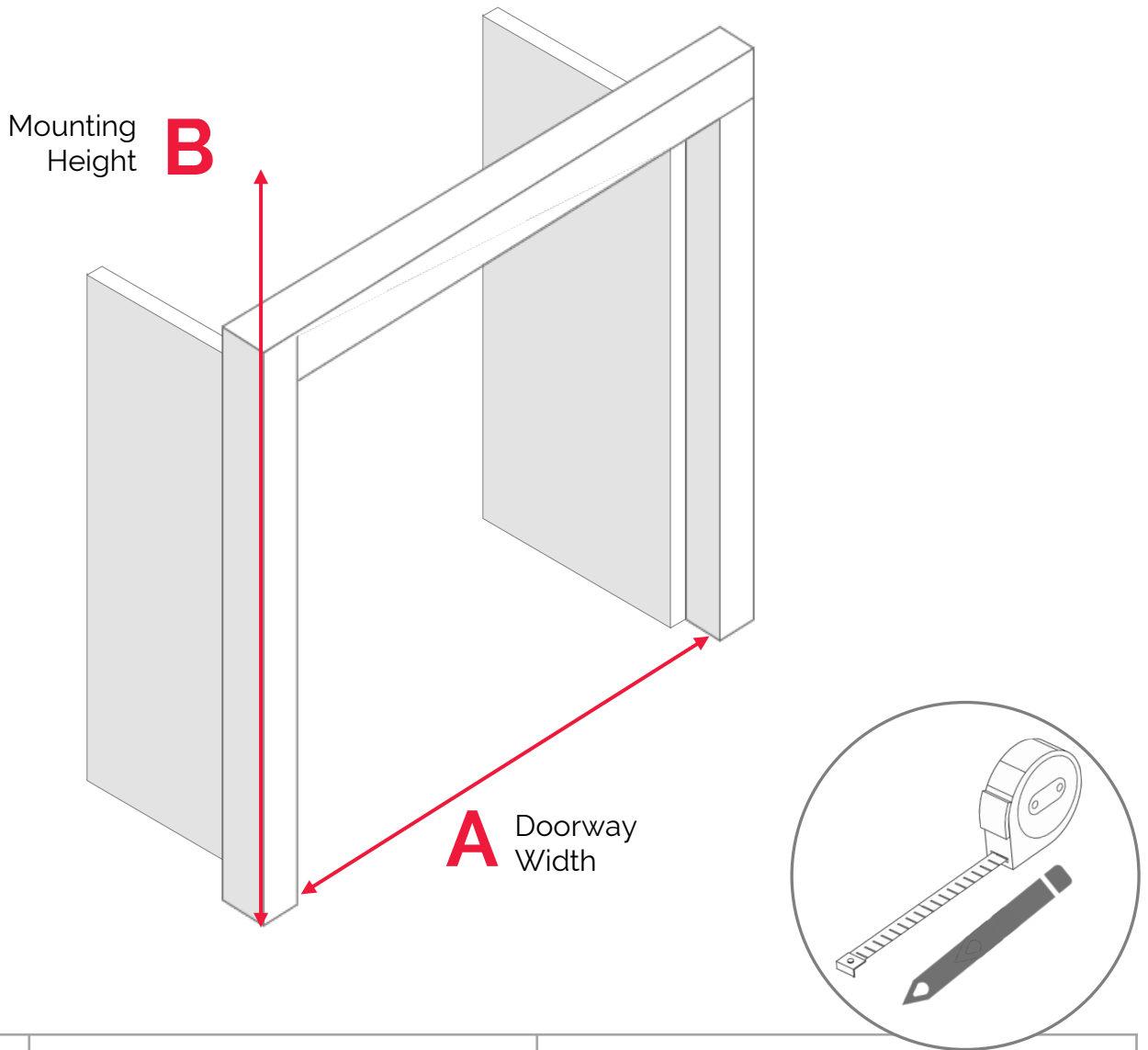

A	Doorway Width (Maximum)	
B	Ceiling or Installation Height	

4 PRIMARY SENSOR INSTALLATION

To ensure that the Base Plate of your SafeCount Primary Sensor is ceiling mounted, the correct distance back from your chosen doorway, you should use the quick reference table below in-conjunction with your **A** and **B** measurements, to determine **C**.

A Doorway Width	B Minimum Mounting Height*	C Distance From Doorway
Up to 195cm (76in)	250cm (98in)	45-59cm (18-23in)
196-230cm (77-90in)	275cm (108in)	51-72cm (20-28in)
231-265cm (91-104in)	300cm (118in)	64-84cm (25-33in)
266-335cm (105-132in)	350cm (138in)	76-110cm (30-43in)
336-410cm (133-161in)	400cm (157in)	89-135cm (35-53in)

*The minimum mounting height is 250cm and Sensors should never be installed below this height. The maximum mounting height of any SafeCount Sensor should never exceed 450cm (177in)

Place the Base Plate on to the ceiling, the correct distance back from the doorway. The 'Distance from Doorway' measurement (**C**) is the total distance from the door to the **bottom of the Base Plate**. The **arrow** on the Base Plate should point into the building and away from the door, with a clear view to the floor.

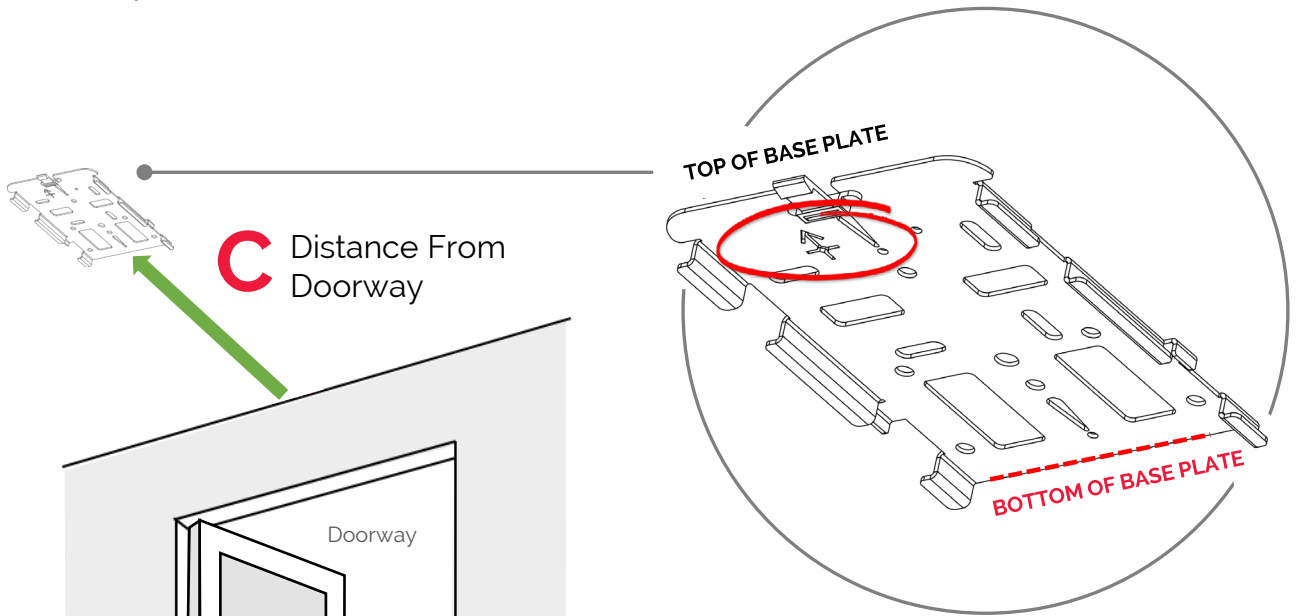

4 PRIMARY SENSOR INSTALLATION



If the ceiling height at the correct distance from doorway (**C**) is greater than the maximum recommend Sensor mounting height of 450cm (177in), then a suitable mounting pole should be used.

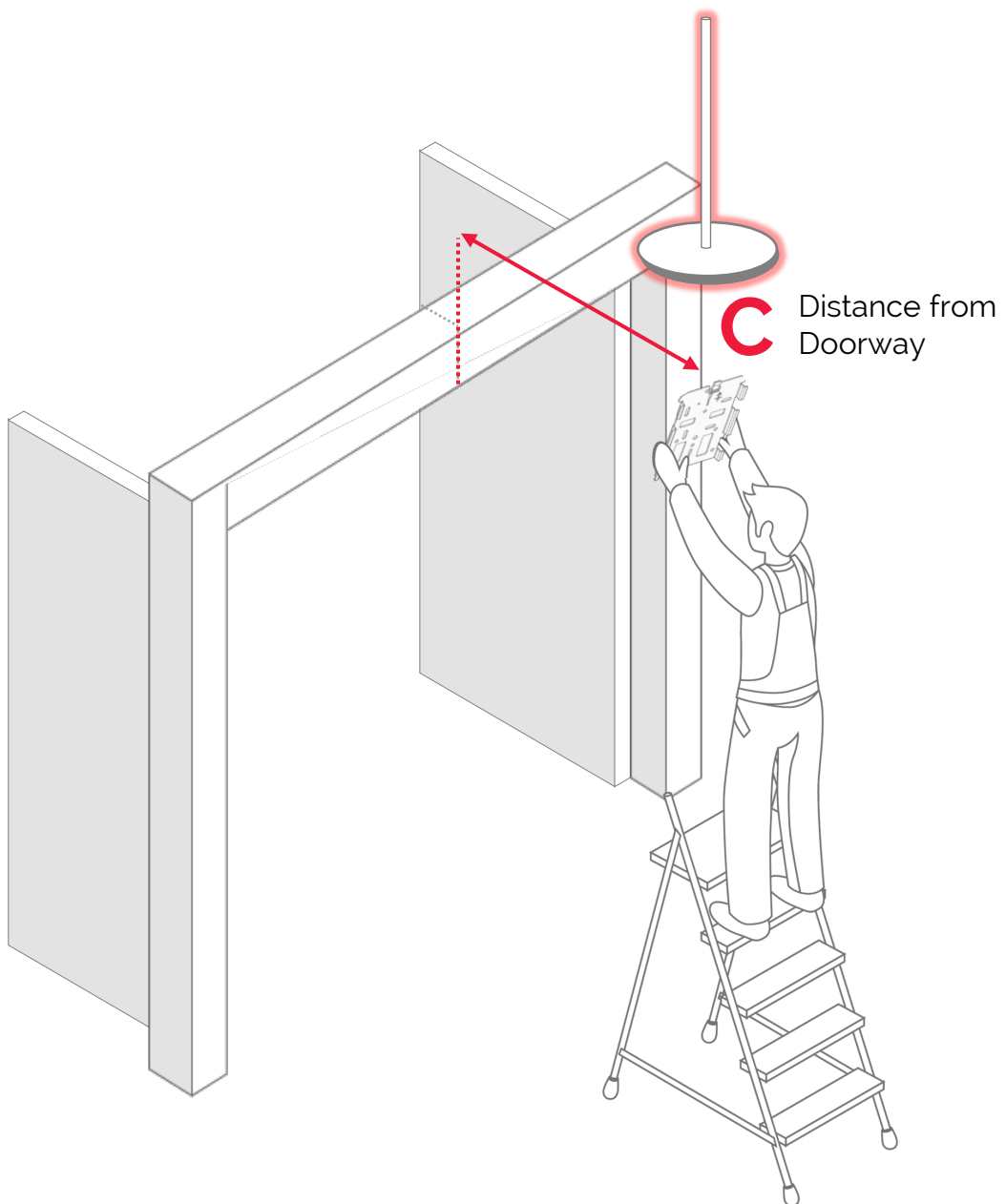

4 PRIMARY SENSOR INSTALLATION



Ensure that your SafeCount Primary Sensor is mounted level, with the lenses pointing straight down.

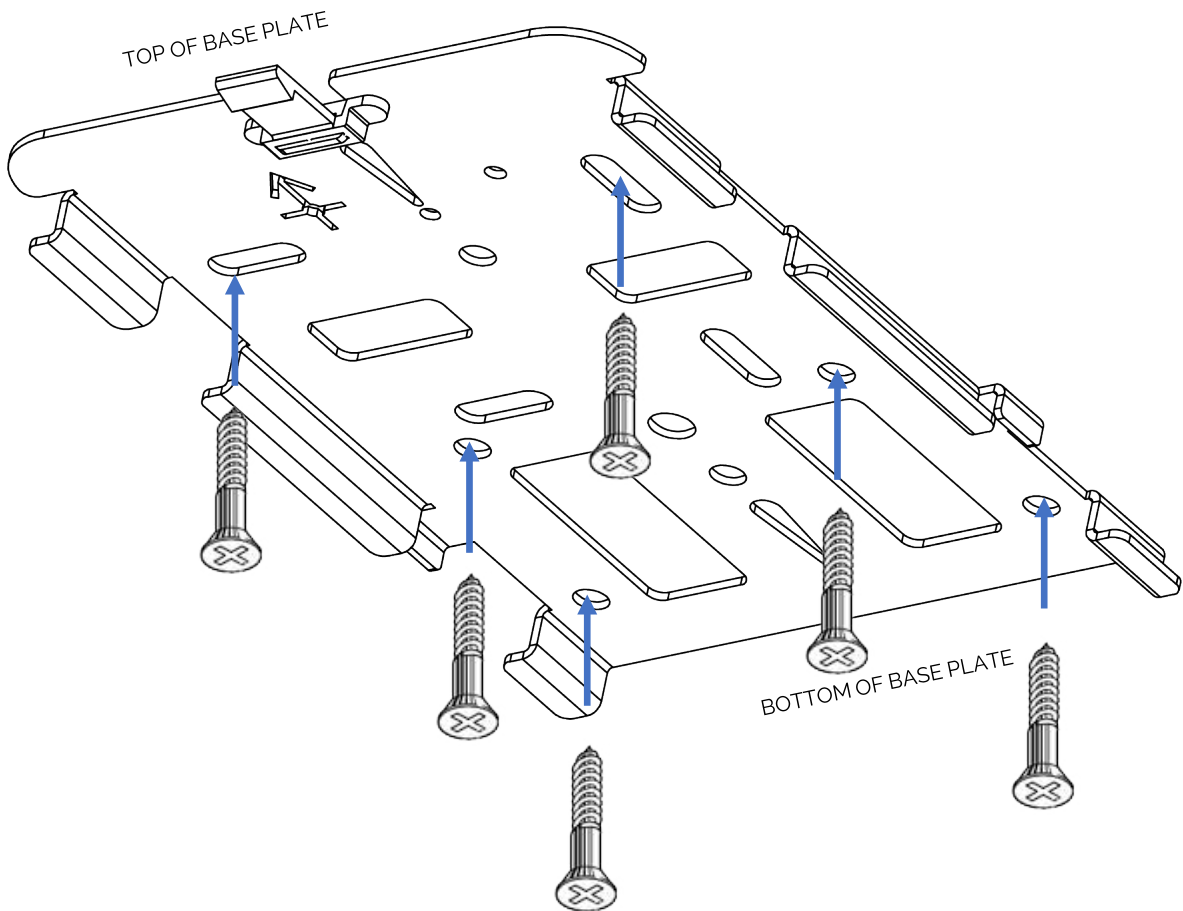

As your SafeCount Primary Sensor weighs approx. 550g (19.4oz), we would always recommend that you use appropriate fixings to secure the base plate in place.



Take care not to distort the base by over tightening fixings, especially if using an electric screwdriver.

4 PRIMARY SENSOR INSTALLATION

Once you have installed the Base Plate, you will need to cut a hole in the ceiling for cable access. The Sensor body is larger than the Base Plate so locate the area marked below and feed your ethernet cable through ready for connection.

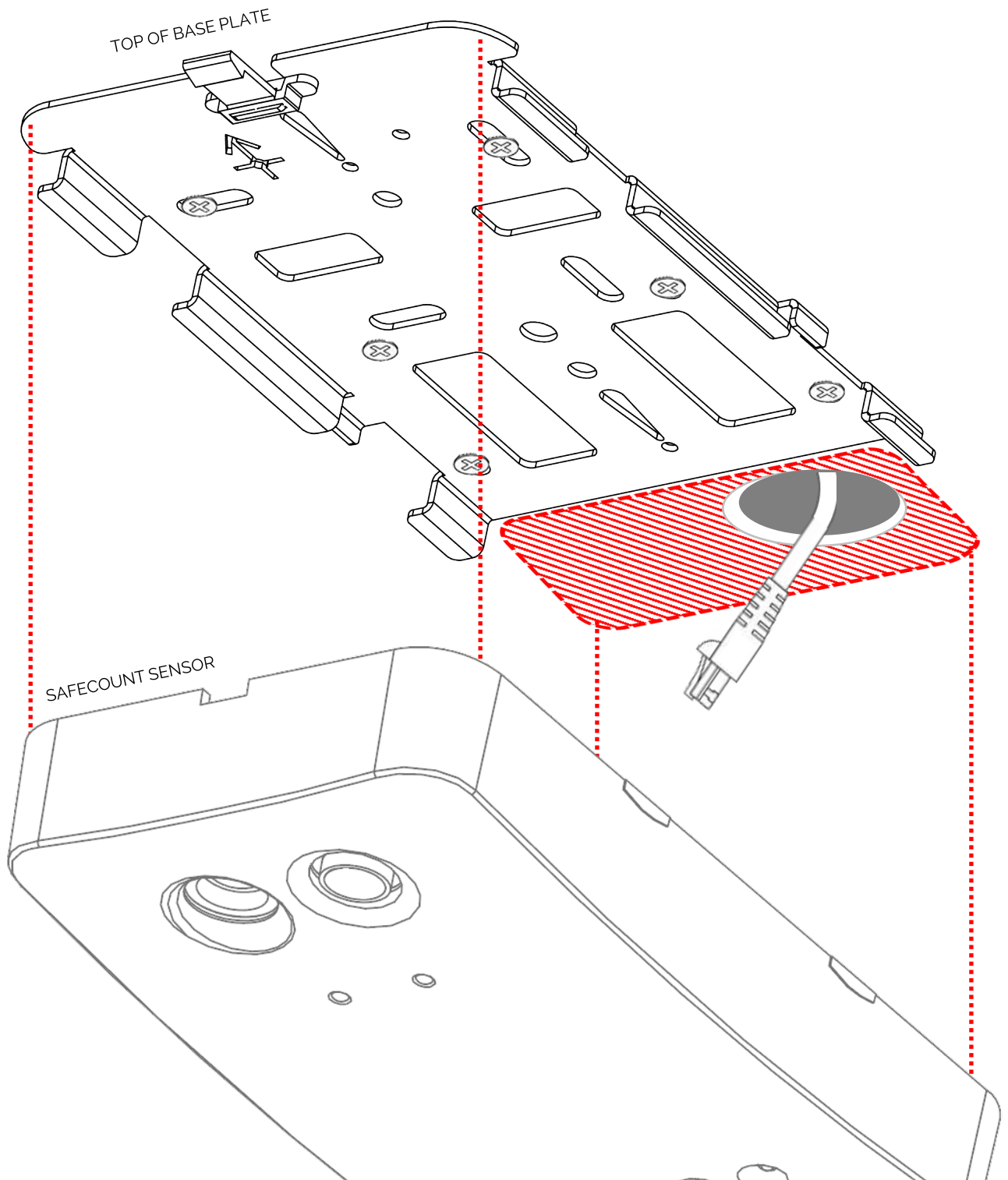

4 PRIMARY SENSOR INSTALLATION

You are now ready to connect the Ethernet Cable to the Network Cable Connection Socket on the SafeCount Primary Sensor and then slide the Sensor onto the base plate. Ensure that the plastic clip on the Base Plate clicks into place when the Sensor is fitted..

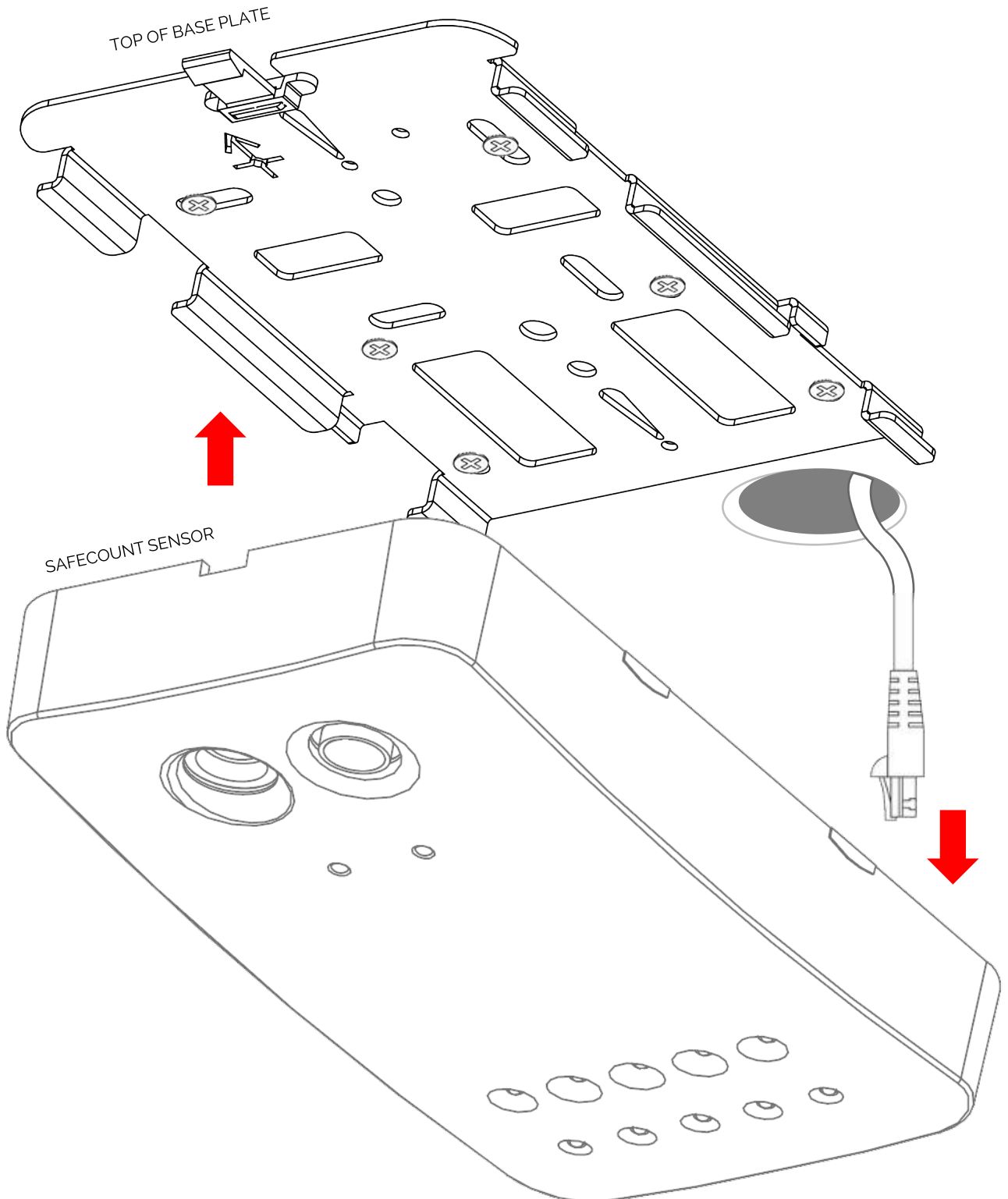

4 PRIMARY SENSOR INSTALLATION

Your SafeCount Primary Sensor should now power up. This is indicated by the two LEDs on the front of the device showing RED initially then flashing various sequences.

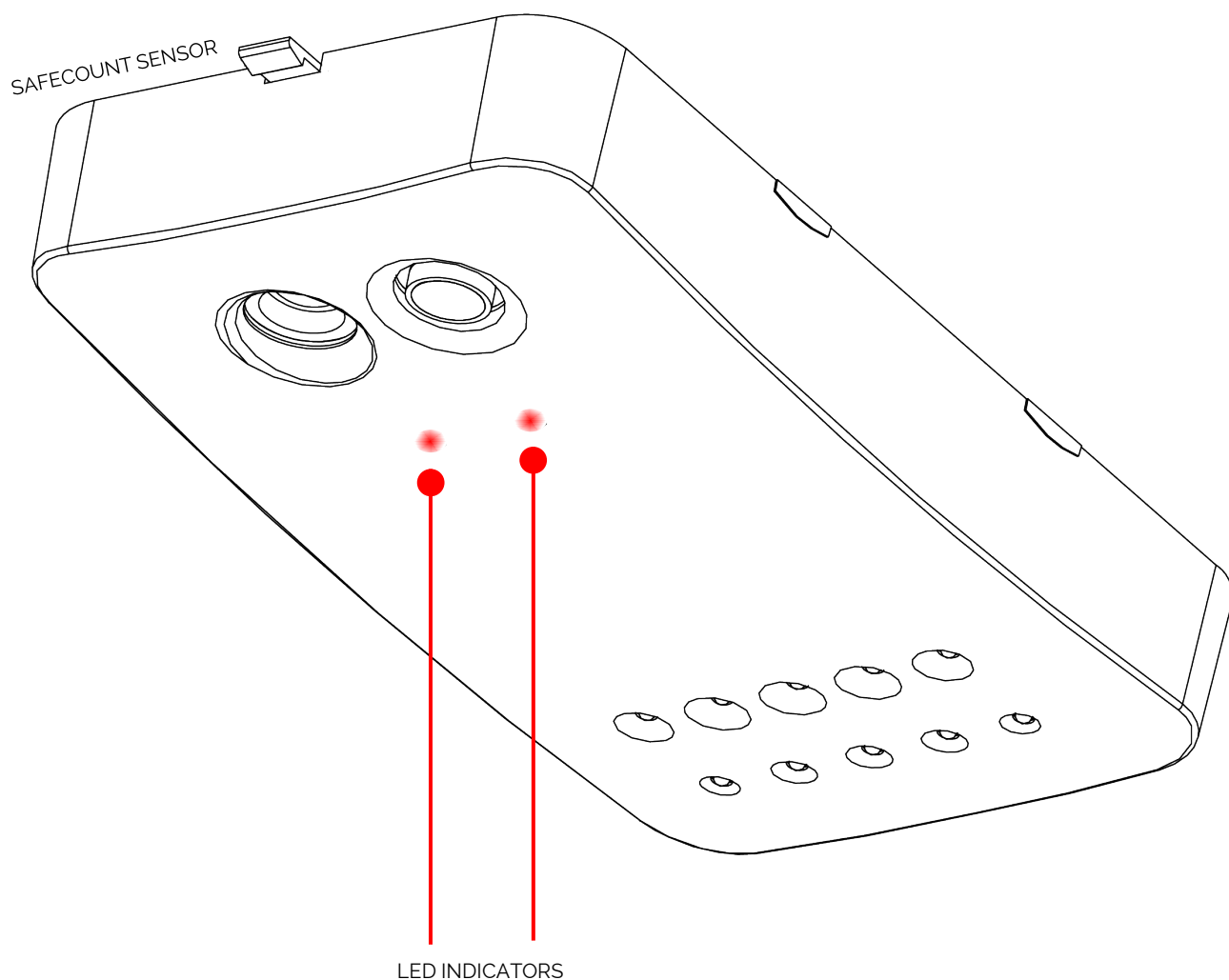

If the LEDs do not illuminate double check your connections and ensure that your PoE switch is powered up correctly.

For more information regarding the LED indicators please refer to '[Section 7](#) – Understanding Device LEDs'.

5 SECONDARY SENSOR INSTALLATION

If you have multiple entrances/exits and wish to cover these with SafeCount Secondary Sensors, then simply follow the same instructions as for the SafeCount Primary Sensor above (**Section 4**) and ensure that the SafeCount Secondary Sensors are connected to the same PoE switch and (WiFi) Router on your network.

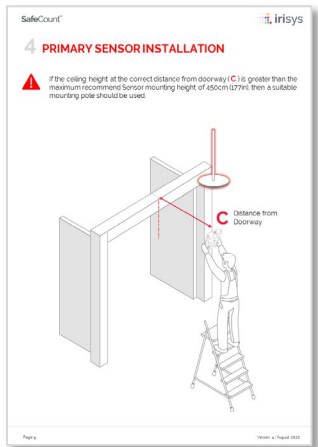
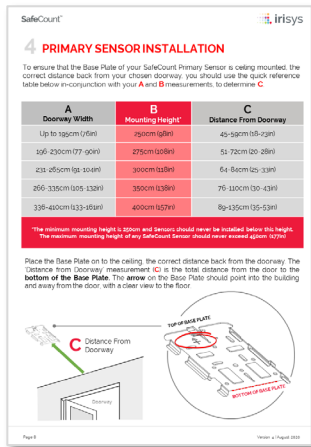
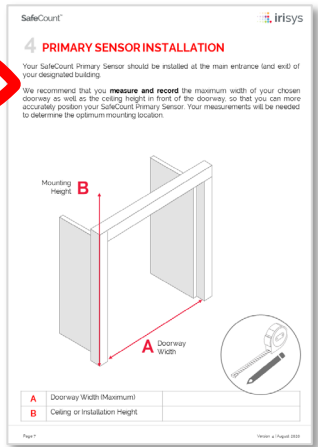

SafeCount Primary Sensor
Installed at Primary Entrance

SafeCount Secondary Sensors
Installed at Secondary Entrances (Up to maximum of 20)

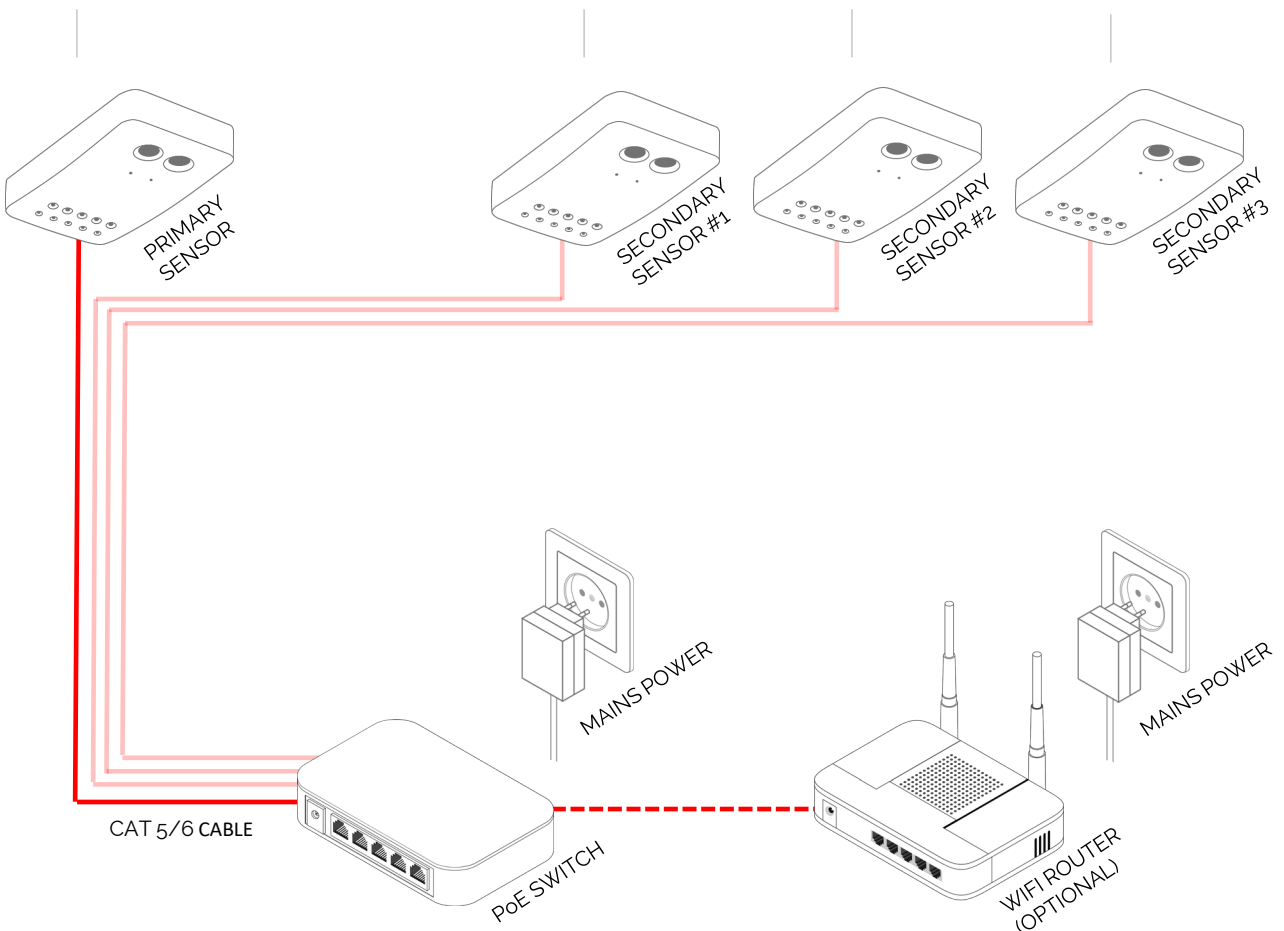

6 SYSTEM CONFIGURATION

Once you have installed all the SafeCount Sensors that you require, you will need to run through the simple configuration wizard in order complete the setup.

CONNECTION VIA (WIFI) ROUTER

- Connect your laptop/mobile device to your WiFi router (wired or wireless)
- Locate the SafeCount Sensor serial number on the box (or back of SafeCount sensor)
- Use your web browser (we recommend Google Chrome) to navigate to the address below:

http://*yourserialnumber*.local/safecount/
e.g. **http://V4D-20200133.local/safecount/**



- A **LOGIN FORM** will appear

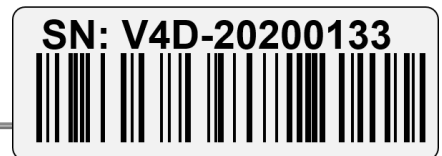
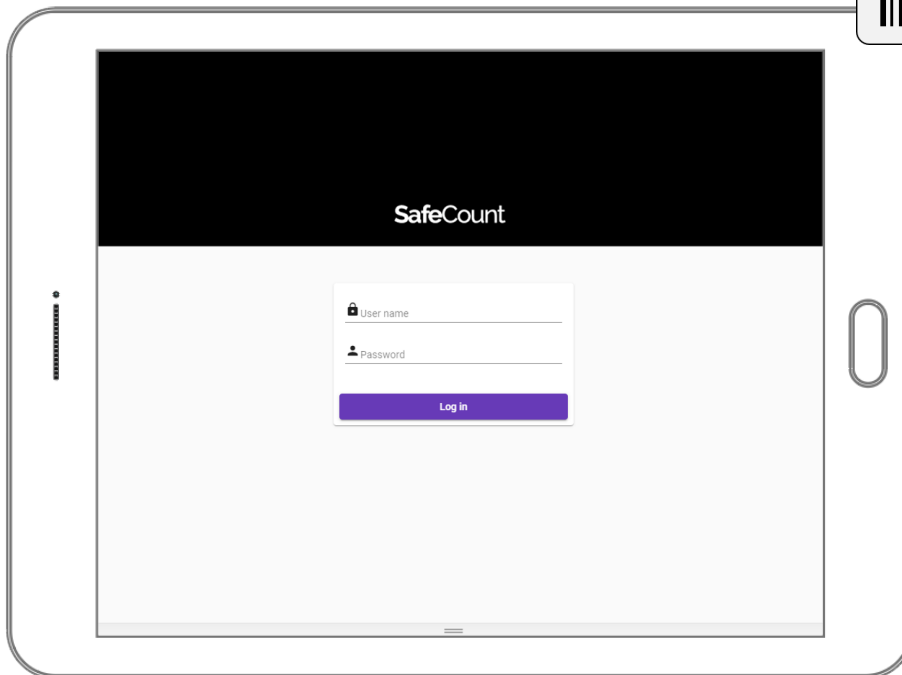

- To proceed you will need to enter the following credentials:

USERNAME: admin
PASSWORD: installer

- Follow the on-screen instructions

6 SYSTEM CONFIGURATION

If you do not have a WiFi Router then you will need to follow the steps below using a physical (wired) connection to the PoE Switch instead.

CONNECTION NOT VIA (WIFI) ROUTER

- Connect your laptop/computer to the same PoE Switch as your SafeCount Sensor(s)
- Each SafeCount Sensor ships with a default IP address of 192.168.0.10, so you will need to ensure that you have set a manual IP Address for your laptop/computer in the same range as the SafeCount Sensor address in order to connect
- Use your web browser (we recommend Google Chrome) to navigate to the address below:

<http://192.168.0.10/safecount/>

- A **LOGIN FORM** will appear

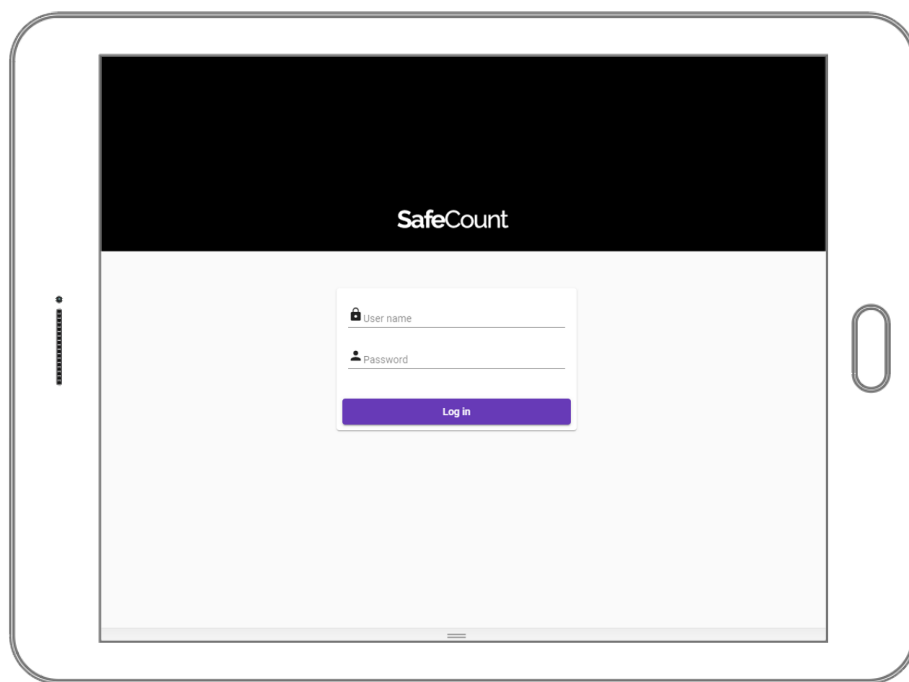

- To proceed you will need to enter the following credentials:

USERNAME: admin
PASSWORD: installer

- Follow the on-screen instructions

6 SYSTEM CONFIGURATION

Once you have successfully logged in to the SafeCount System for the first time the Setup Wizard will automatically guide you through the basic configuration steps.

SETUP WIZARD – NETWORK SETUP

You will initially be asked about the **Network Settings** that your SafeCount Sensor will be using when connected to your network.

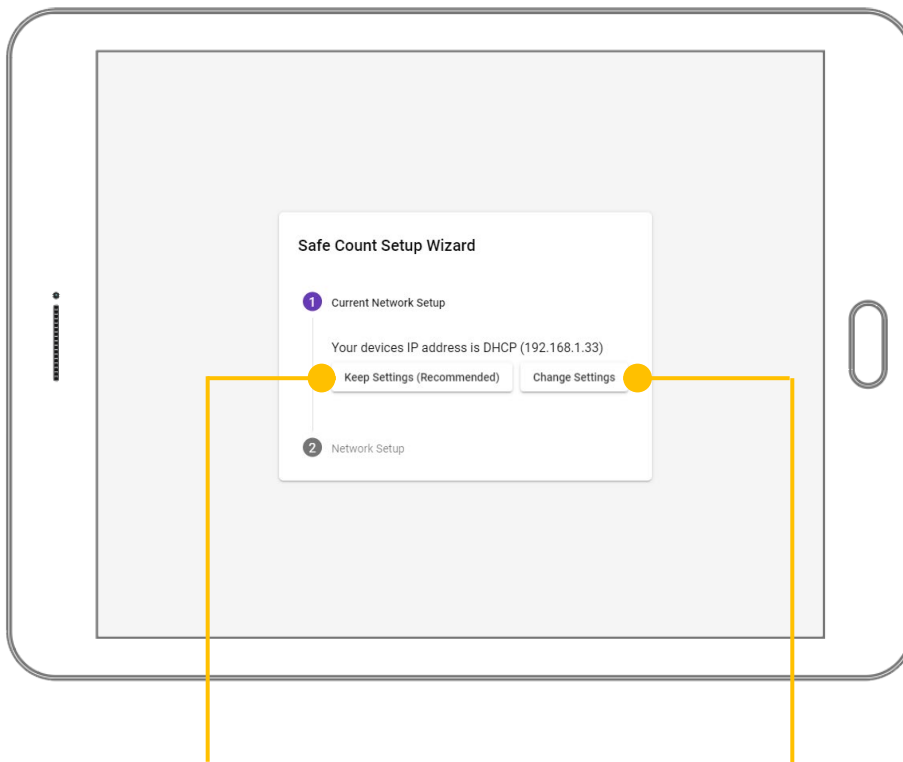

KEEP SETTINGS

An IP address will automatically be assigned to your SafeCount Sensor if you have a DHCP server (router) on your network. We recommend keeping this dynamic address.

Selecting this option will take you to the next section of the **Setup Wizard**

CHANGE SETTINGS

Should you wish to manually assign an IP address to your SafeCount Sensor you can do so by selecting this option. If selected an additional **Network Setup** screen will appear allowing you to configure as required.

6 SYSTEM CONFIGURATION

If you opt to manually assign an IP address to your SafeCount Sensor then a basic knowledge of network configuration. Is assumed

SETUP WIZARD – NETWORK SETUP – MANUAL CONFIGURATION

Here you can manually configure the IP address and associated network settings.

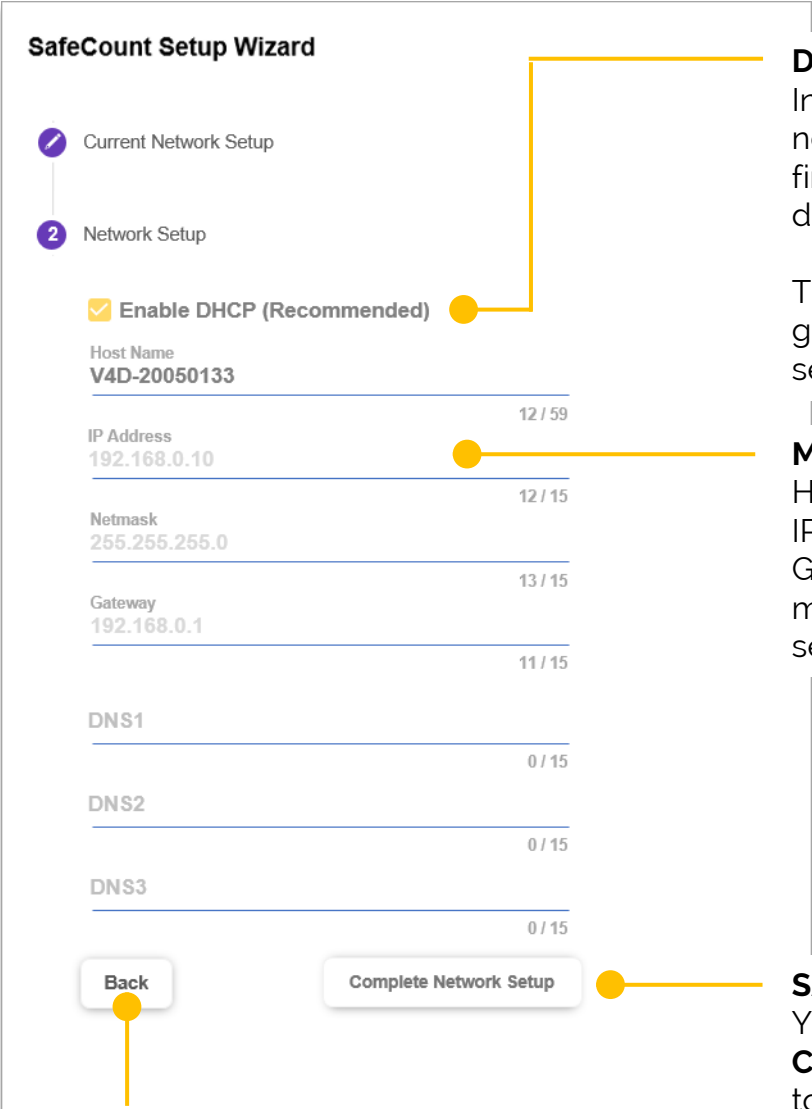

DISABLE DHCP

In order to be able to edit the network settings manually, you will first need to de-select (untick) the default (recommended) option

The network settings will remain greyed out until this option is de-selected.

MANUAL SETTINGS

Here you can manually assign the IP address, subnet mask and Gateway IP address as well as manually setting any domain name server (DNS) addresses.

SAVE SETTINGS

You will need to click on the **Complete Network Setup** option to save your manual configuration. Doing so will enable you to move to the rest of the setup wizard

CANCEL CONFIGURATION

Selecting this option will take you back to the previous screen with an automatically assigned (DHCP) IP address

6 SYSTEM CONFIGURATION

With the Network Setup complete you will be taken to the next stage of the Setup Wizard as detailed below.

SETUP WIZARD – SITE DETAILS

Here you will be asked to complete information specific to the location of the SafeCount Sensor(s) being installed.

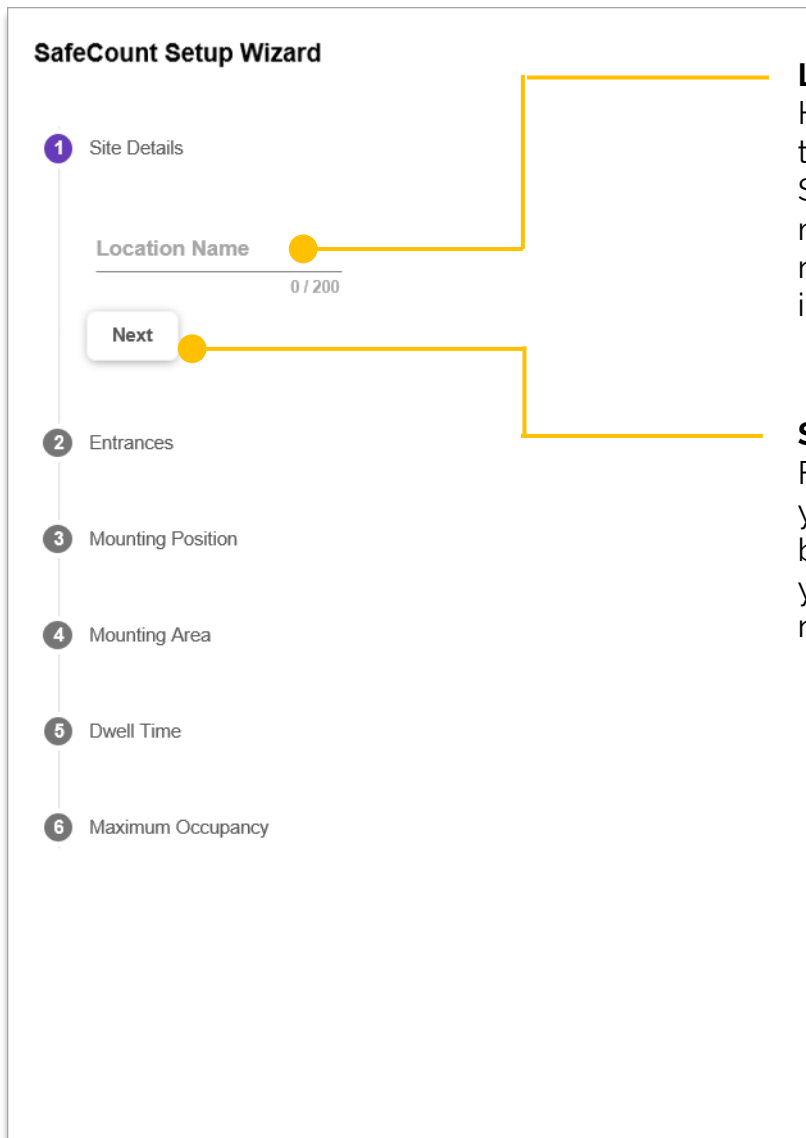

The screenshot shows the 'SafeCount Setup Wizard' interface. On the left, a vertical progress bar lists six steps: 1 Site Details, 2 Entrances, 3 Mounting Position, 4 Mounting Area, 5 Dwell Time, and 6 Maximum Occupancy. Step 1 is highlighted with a purple circle. The main content area shows a 'Location Name' input field with a yellow dot indicating the cursor position and a character count of '0 / 200'. Below the input field is a 'Next' button with a yellow dot. A yellow line connects the 'Next' button to the 'LOCATION NAME' section on the right.

LOCATION NAME

Here you should enter a name for the location where the SafeCount Sensor has been installed. This might typically be a company name and geographical location i.e. FIRST RETAIL - OXFORD

SAVE & CONTINUE

For each step of the Setup Wizard you will need to select the **Next** button which will save any changes you make and progress you to the next setting

6 SYSTEM CONFIGURATION

The main section of the Setup Wizard needs to be completed in order to complete the installation of your SafeCount Sensor(s).

SETUP WIZARD – ENTRANCES (SINGLE SENSOR)

Continue to enter the information requested in each section of the Setup Wizard.

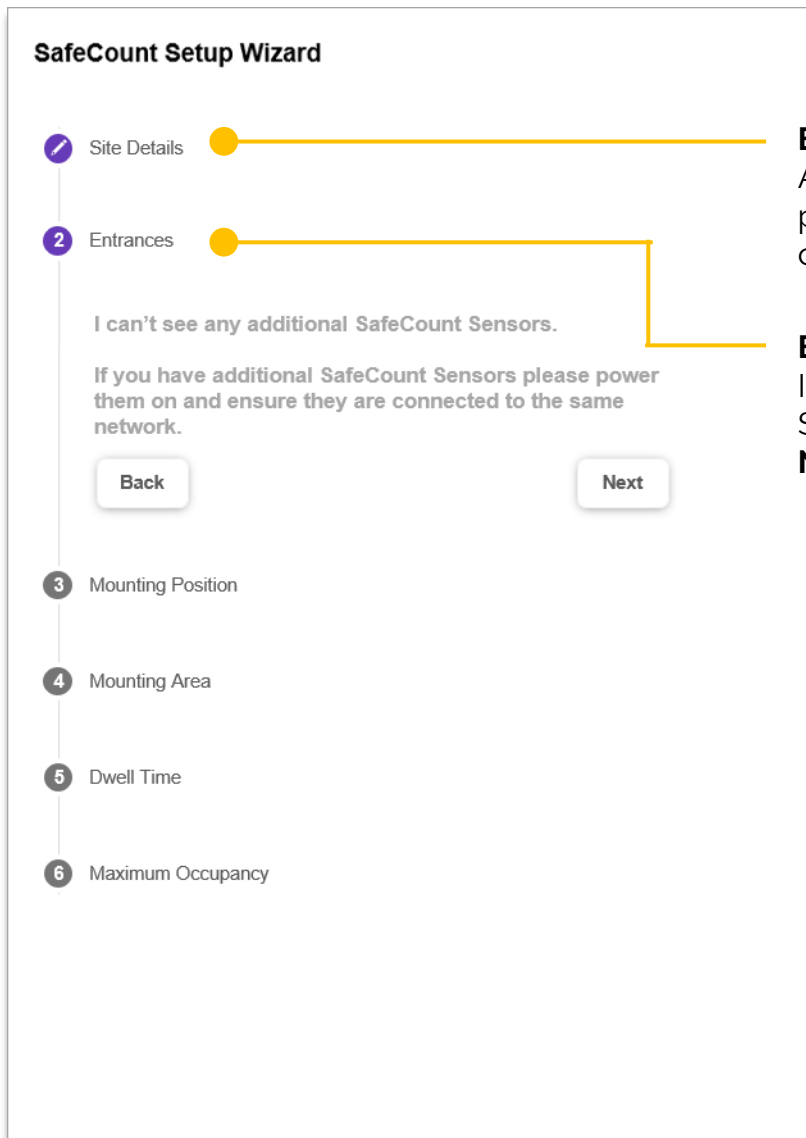

SafeCount Setup Wizard

1 Site Details

2 Entrances

I can't see any additional SafeCount Sensors.

If you have additional SafeCount Sensors please power them on and ensure they are connected to the same network.

Back Next

3 Mounting Position

4 Mounting Area

5 Dwell Time

6 Maximum Occupancy

EDIT PREVIOUS ENTRIES

An edit icon will appear against any previous entries, allowing you to click on them and edit if required.

ENTRANCES

If you are just installing the one SafeCount Sensor then simply click **Next** to continue.

6 SYSTEM CONFIGURATION

The main section of the Setup Wizard needs to be completed in order to complete the installation of your SafeCount Sensor(s).

SETUP WIZARD – ENTRANCES (MULTI SENSOR)

Continue to enter the information requested in each section of the Setup Wizard.

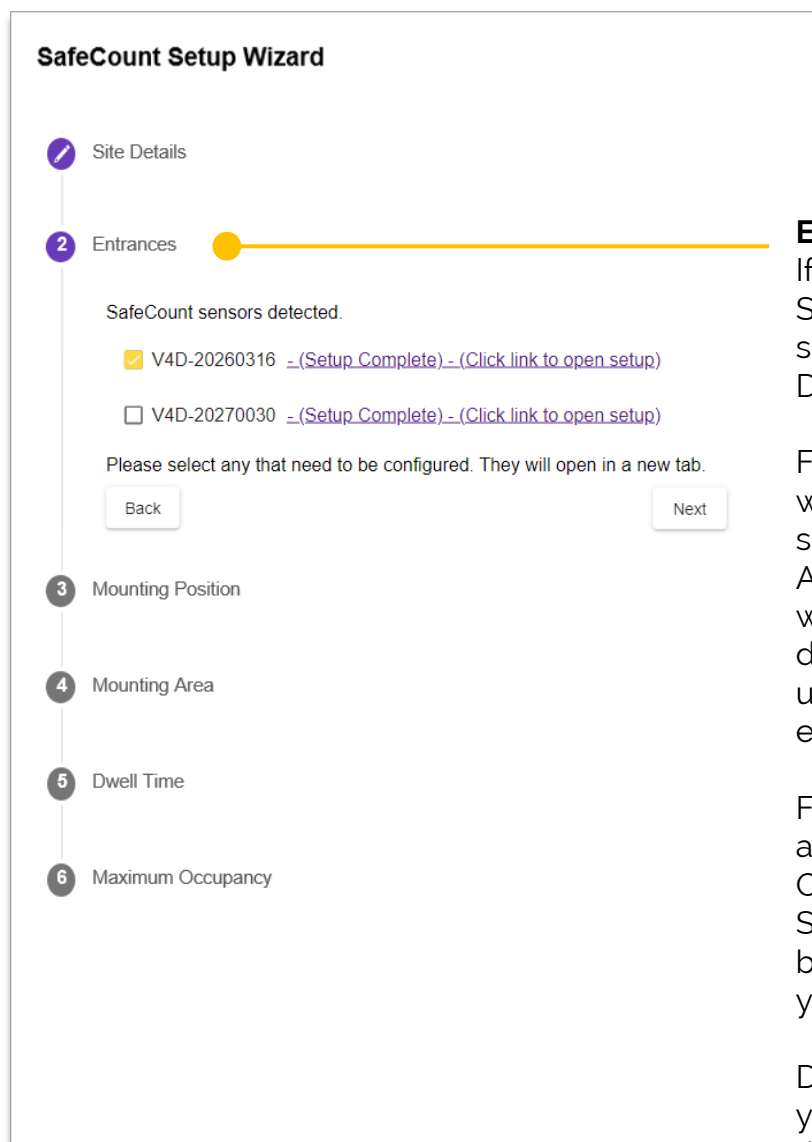

SafeCount Setup Wizard

1 Site Details

2 Entrances

SafeCount sensors detected.

V4D-20260316 [-\(Setup Complete\) - \(Click link to open setup\)](#)

V4D-20270030 [-\(Setup Complete\) - \(Click link to open setup\)](#)

Please select any that need to be configured. They will open in a new tab.

3 Mounting Position

4 Mounting Area

5 Dwell Time

6 Maximum Occupancy

ENTRANCES

If you are installing multiple SafeCount Sensors then at this stage your SafeCount Secondary Devices should be visible and listed.

For each Secondary sensor you wish to connect to this Primary sensor, click the setup link. A new Browser Window (or Tab) will open for each Secondary device and you will need to log in using the credentials provided earlier (see pages 16-17).

Follow the Setup Wizard until advised that setup is complete. Once your SafeCount Secondary Sensor has been configured, it will be marked as **Setup Complete** and you should now tick the checkbox.

Do this for all Secondary devices you want to connect and ensure their checkboxes are ticked before clicking **Next** and continuing with the Setup of your SafeCount Primary Sensor.

6 SYSTEM CONFIGURATION

The main section of the Setup Wizard needs to be completed in order to complete the installation of your SafeCount Sensor(s).

SETUP WIZARD – MOUNTING POSITION

Continue to enter the information requested in each section of the Setup Wizard.

SafeCount Setup Wizard

- 1 Site Details
- 2 Entrances
- 3 Mounting Position**
- 4 Mounting Area
- 5 Dwell Time
- 6 Maximum Occupancy

Is the SafeCount Sensor pointing towards or away from the door?

 AWAY From Door

 TO The Door

SENSOR ORIENTATION

It is important that you check the orientation of your installed Sensor and select the entry that matches from those illustrated.

Simply click **Next** to continue once the appropriate **Mounting Position** has been selected.

6 SYSTEM CONFIGURATION

The main section of the Setup Wizard needs to be completed in order to complete the installation of your SafeCount Sensor(s).

SETUP WIZARD – MOUNTING AREA

Continue to enter the information requested in each section of the Setup Wizard.

SafeCount Setup Wizard

- Site Details
- Entrances
- Mounting Position
- 4 Mounting Area ●
- 5 Dwell Time
- 6 Maximum Occupancy

Is the SafeCount Sensor mounted inside or outside the occupancy area?

Occupancy Area

INSIDE
Area
SafeCount
Sensor

Occupancy Area

OUTSIDE
Area
SafeCount
Sensor

Back

Next

MOUNTING AREA

It is important that you select the correct **Mounting Area** for your Sensor, relative to the **Occupancy Area**, as per the illustrations provided.

If your Sensor is mounted inside the Occupancy Area select **Inside Area**, otherwise select **Outside Area**.

Simply click **Next** to continue once the appropriate **Mounting Area** has been selected.

6 SYSTEM CONFIGURATION

The main section of the Setup Wizard needs to be completed in order to complete the installation of your SafeCount Sensor(s).

SETUP WIZARD – DWELL TIME

Continue to enter the information requested in each section of the Setup Wizard.

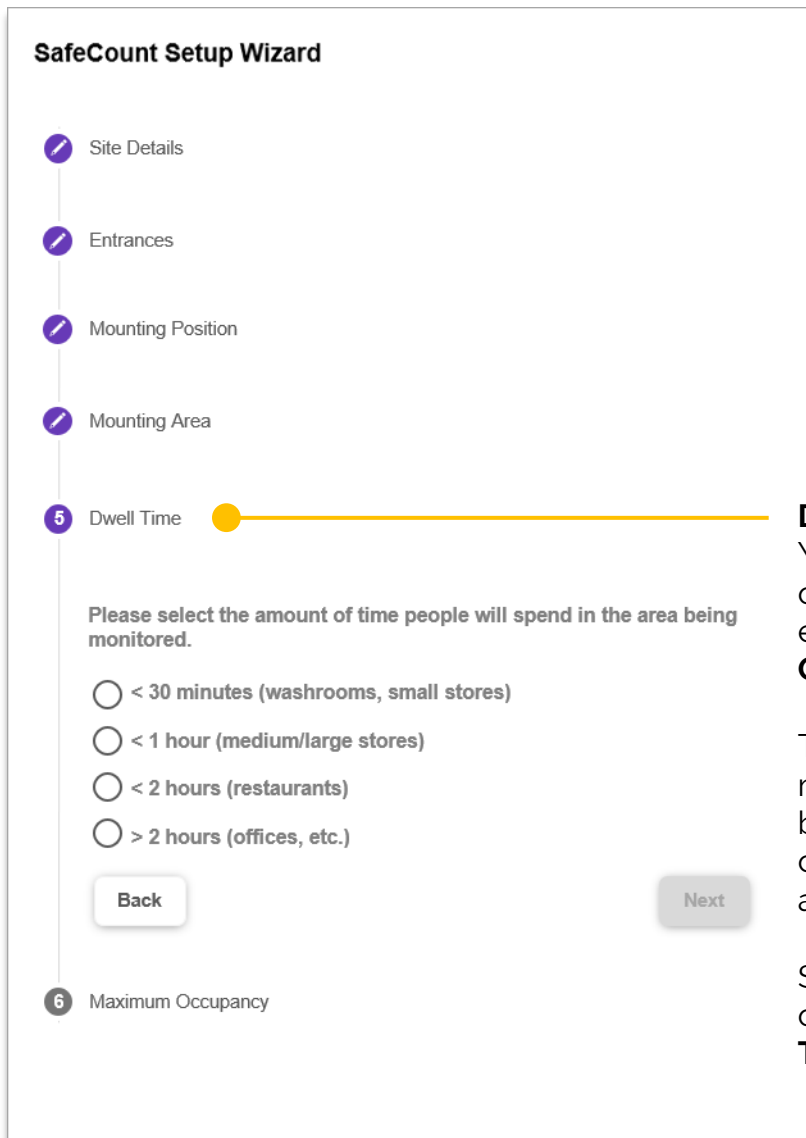

SafeCount Setup Wizard

- Site Details
- Entrances
- Mounting Position
- Mounting Area
- 5 Dwell Time**
- 6 Maximum Occupancy

Please select the amount of time people will spend in the area being monitored.

- < 30 minutes (washrooms, small stores)
- < 1 hour (medium/large stores)
- < 2 hours (restaurants)
- > 2 hours (offices, etc.)

DWELL TIME

You should select the amount of time you would typically expect people to spend in the **Occupancy Area**.

The selected **Dwell Time** is merely an approximate value, but this setting provides context for the detection algorithms.

Simply click **Next** to continue once the appropriate **Dwell Time** has been selected.

6 SYSTEM CONFIGURATION

The main section of the Setup Wizard needs to be completed in order to complete the installation of your SafeCount Sensor(s).

SETUP WIZARD – MAXIMUM OCCUPANCY

Enter the final set of information requested in this section of the Setup Wizard.

SafeCount Setup Wizard

- ✓ Site Details
- ✓ Entrances
- ✓ Mounting Position
- ✓ Mounting Area
- ✓ Dwell Time
- 6** Maximum Occupancy

High Customers (Warning at) Limit	Max Customers (Full at) Limit
0 / 200	0 / 200

Back

Complete Setup

OCCUPANCY LIMITS

Here you should set the **Maximum Customer Limit** that the chosen occupancy area can support at any one time, so that the customer facing display options can limit further entry.

The **High Customers Limit** is used to notify when the Maximum Customer Limit is closed to being reached.

Once the appropriate **Occupancy** parameters have been entered you should click on **Complete Setup** to end the Setup Wizard.

7 UNDERSTANDING DEVICE LEDS

The following information relates to the SafeCount Sensor LEDs (x2) and the relevant device status each sequence represents. These are useful for troubleshooting and reporting problems to Irisys.

GENERAL

DESCRIPTION	LED #1	LED #2	NOTES
Power On / Boot	Solid RED Solid YELLOW Solid GREEN Pulse BLUE	Solid RED Solid YELLOW Solid GREEN Pulse BLUE	Total time is about 30 seconds to boot, and it will go through each of these at some point in that time.
Factory Reset Button Depressed	RED alternating pulses	GREEN alternating pulses	After 5 seconds the device will restart and normal boot sequence will be observed
Heartbeat	1 RED blip	1 RED blip	Regular 'heartbeat' signal every few seconds, once device is configured
Height Auto-Config	BLUE Alternate	BLUE Alternate	Occasionally observed when the "auto-detect height" button has been pressed
Certificate Is Being Generated	YELLOW Alternate	GREEN Alternate	Occasionally observed in new devices as TLS security certificates are auto-generated

WARNING / ERROR

DESCRIPTION	LED #1	LED #2	NOTES
Unconfigured / Illegal Configuration	Solid YELLOW	1 RED Pulse	This is the normal sequence after boot for a newly installed device
Height detection config failure	Solid YELLOW	2,3 or 4 RED Pulses	Check the devices is correctly installed and pointing downwards; check field of view is unobstructed
Internet connectivity check	Solid YELLOW	1 GREEN Pulse	The device cannot connect out – this is perfectly normal and is expected behaviour on a stand-alone system
Device Communication network failure	Solid YELLOW	2 or 3 GREEN Pulses	Check that devices are able to communicate with each other
Infrared LED illuminators are (temporarily) disabled	Solid YELLOW	1 BLUE Pulse	This is normal if device is facing up or on its side. Check device is correctly mounted on ceiling
Device Failure	Solid RED	Various pulses of BLUE, RED or YELLOW	In rare occasion of device failure, please contact Irisys; note that 2 BLUE pulses may indicate that the SD Card has been ejected (check)

8 DISCLAIMER

© 2020 InfraRed Integrated Systems Limited (Irisys). No part of this publication may be reproduced without prior permission in writing from Irisys. This document gives only a general description of the products and except where expressly provided otherwise shall form no part of any contract. While Irisys will endeavor to ensure that any data contained in this product information is correct, Irisys do not warrant its accuracy or accept liability for any reliance on it. Irisys reserve the right to change the specification of the products and descriptions without notice. Prior to ordering products please check with Irisys for current specification details. This product may be protected by patents US 5420419, US 5895233, US 6239433, US 6693279, US 6528788, US 7778855, EP 0853237, EP 1079349, GB 2476500, JP 3998788, JP 4376436; other patents pending, . All brands and product names are acknowledged and may be trademarks or registered trademarks of their respective holders.

This Irisys product contains software originating from Irisys and its suppliers that is licensed under the Irisys Software License Agreement.

This Irisys product also contains software from the open source community that is licensed under the specific license terms applicable to that software. The full details of these license agreements, and warranties, are either embedded in the product interface, or can be obtained on written request. In keeping with Irisys' obligations to said open-source licenses, this document should be taken as written offer, valid for three years, to provide a complete machine-readable copy of the corresponding source code, distributed in accordance with the license, upon request. Any written correspondence on this matter should be addressed to: Open Source Software Coordinator, Irisys, Tithe Barn Way, Northampton NN4 9BG, United Kingdom.



 **InfraRed Integrated Systems Ltd**
Park Circle, Tithe Barn Way, Swan Valley
Northampton NN4 9BG
United Kingdom

 +44 (0)1604 594200

 sales@irisys.co.uk

 www.irisys.net

Part of Fluke since 2012



© 2020 InfraRed Integrated Systems Limited (Irisys). No part of this publication may be reproduced without prior permission in writing from Irisys. Whilst Irisys will endeavour to ensure that any data contained in this document is correct, Irisys do not guarantee its accuracy or accept liability for any reliance on it. Irisys reserve the right to change the specification of the products and description without notice. Prior to ordering product please check with Irisys for current specification details. Irisys products may be protected by patents. All brands, products and names are acknowledged and may be trademarks or registered trademarks of their respective holders.